

The MegaPhase logo features a stylized, glowing orange and yellow 'S' shape within a circular gradient background, with a thin orange line extending from the top left of the circle.

MegaPhase®

A purple-tinted background image showing a satellite being launched from a rocket, with various antennas and equipment visible on the launch pad.

CONNECTOR AND ADAPTER CATALOG

A purple-tinted background image showing several different types of connectors and adapters, including coaxial and SMA connectors, arranged diagonally.

**WITH THE RIGHT
CONNECTIONS,
ANYTHING IS
POSSIBLE.**

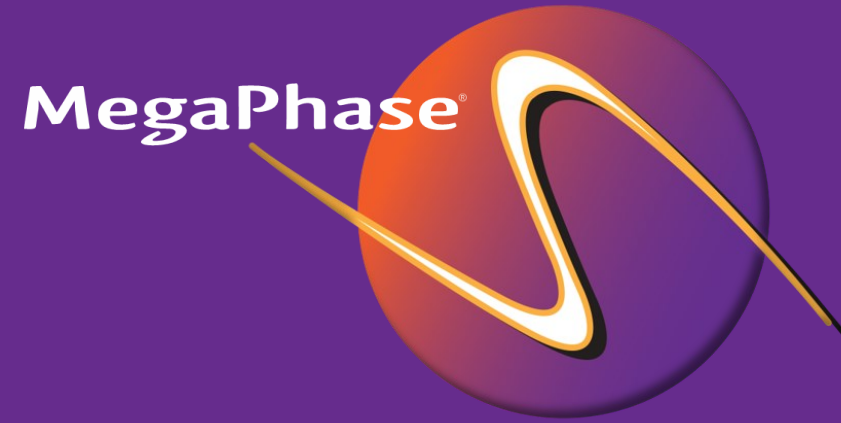

WITH THE RIGHT CONNECTIONS, ANYTHING IS POSSIBLE.

The cables & RF components in your electronic system may not be the most important components to you, but they're everything to us.

We design and manufacture cables & RF components with the understanding that if a connection fails, it can take your whole system with it.

That's why our products are known for superior phase & amplitude stability, excellent measurement repeatability, and extra rugged mechanical strength. It's why we developed a unique GrooveTube® outer conductor technology that wraps our cable in a flexible "armor."

And why every component shipped from MegaPhase is thoroughly tested and retested.

We also provide a powerful warranty, the most responsive deliveries, and highly competitive pricing.

Because doing one thing right just isn't enough.

Not for us; and not for you.

Call us at 1-877-634-2742 or 570-424-8400 or visit us online www.MegaPhase.com

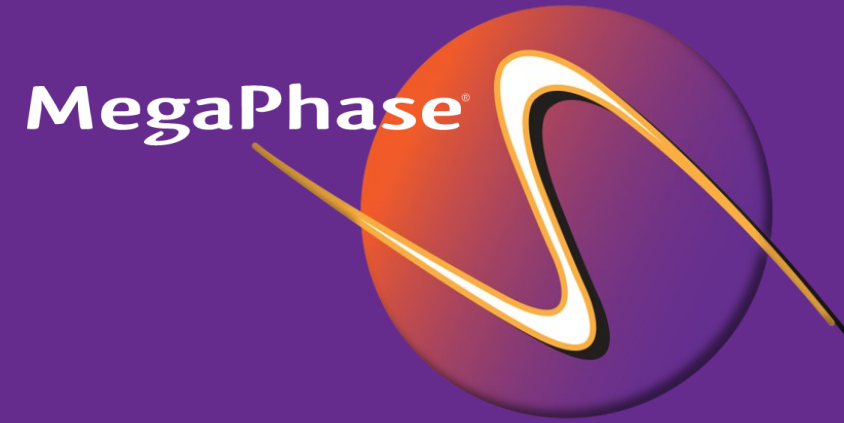

DON'T TAKE OUR WORD FOR IT.

"I wanted to take the moment to thank you for the hasty turn around on our cables that we ordered. The service was fantastic, as always, we will look toward MegaPhase for all of our continued cabling needs."

A senior buyer at a leading space systems company.

"Thank you so much for your prompt response on this matter.

I have made notes in our system to NEVER use [your competitor] again and to try MegaPhase for those needs. Just wanna say thanks again for your help! Have a great day!"

A buyer at a compliance test lab.

"We have always been very satisfied with the quick service and delivery we receive from MegaPhase."

A test engineer at a large semiconductor OEM.

"My guys in [our corporate location] love these MegaPhase cables!
We'll buy more this year."

A senior RF test system designer at a large mobile phone OEM.

Our cables, RF components, our exceptional value, and our incomparable service have our customers – and the entire industry talking.

Give us a call or visit us online and we'll have you talking too.



**With the right connections,
anything is possible.**



Part Numbering

Adapters PN :

CA-K2K2-01X*

(Product Type)-(Connector Type Left, Gender & Conf. Left)-(Connector Type Right, Gender & Conf. Right)-(Running Number)

Reading : Adaptor K Female to K Female Version 01

Naming Convention :

- Numerical connector type goes first. (CA-21K1-01 Not CA-K121-01)
- Smallest Numerical connector type goes first. (CA-1221-01 Not CA-2112-01)
- First alphabetical connector type goes first. (CA-C1K1-01 Not CA-K1C1-01)

The same rules applies to the gender in a second time.

- (CA-K1KC-01 Not CA-KCK1-01)
- (CA-1112-01 Not CA-1211-01)
- (CA-KFKR-01 Not CA-KRCF-01)

Connector PN :

CN-K1-086-01X*

(Product Type)-(Connector Type, Gender & Conf.)-(Cable Type)-(Running Number)

Reading : Cable Connector K Male for 086 version 01

Board Connector PN :

CP-K1-001X*



Part Numbering

Connector Type	Designation
1mm	1
1.85mm	V
2.4mm	2
2.92mm	K
3.5mm	3
7-16	D
7mm	7
BNC	B
C	C
F	F
HN	H
MCX	M
MMCX	MM
N	N
OSP	Q
OSSP	QS
PKZ	P
SC	SC
SMA	S
SMB	J
SMC	A
SMP	G
SMPM	GS
SMP3 (SMPS)	G3
SSMA	SS
SSMB	JS
SSMP	GS
TK	R
TNC	T

Gender & Configuration	Designation
Female Straight	2
Female 90° "Factory Form"	6
Female 90° Cube	8
Female 90° Sweep	4
Female Bulkhead Straight	B
Male Bulkhead Straight	C
Female Front Mount Straight	F
Female Panel Mount Straight	P
Male Panel Mount Straight	Q
Genderless Straight (e.g.--7mm)	9
Male Straight (Hex Nut)	1
Male Straight (1/2 Hex - 1/2 Knurl Nut) for Type N only – Standard	K
Male 90° "Factory Form"	5
Male 90° Cube	7
Male 90° Sweep	3
Ruggedized Female Port Mates with VNA Port Connectors	0
Ruggedized Male Port Replicates VNA Port Connector	R
PCB, Edge Straight Male	E1
PCB, Edge Straight Female	E2
PCB, Surface, 90° Male	E3
PCB, Surface, 90° Female	E4
PCB, Surface, Thru Male	E5
PCB, Surface, Thru Female	E6

Product Type	Designation
Adapters	CA
Connector Block	CB
Connectors	CN
Board Connectors	CP



PRECISION ADAPTERS

The Right Connection For Your Test or System

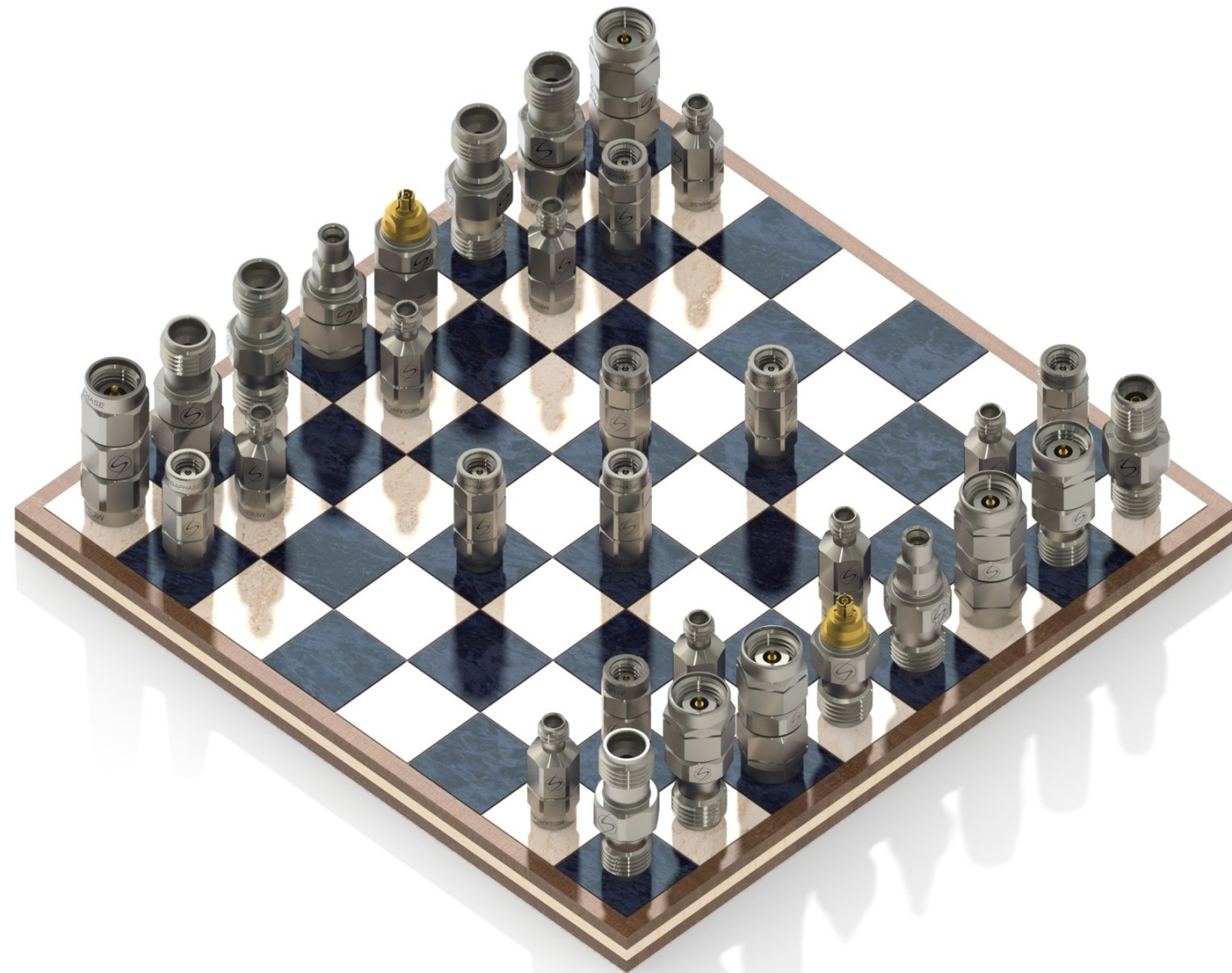

Matrix

	1.0 mm	1.85 mm	2.4 mm	2.92 mm (SMK)	SMP	SMPM	SMP3 (SMPS)
1.0 mm	Pages : 6-7	Page : 18					
1.85 mm	Page : 18	Pages : 8-9	Page : 19			Page : 14-15	
2.4 mm		Page : 19	Pages: 10-11	Page : 20			
2.92 mm (SMK)			Page : 20	Pages : 12-13	Page : 16-17		
SMP				Page : 16-17			
SMPM		Page : 14-15					
SMP3 (SMPS)							Page :



Precision Adapters

1.0 mm Interface

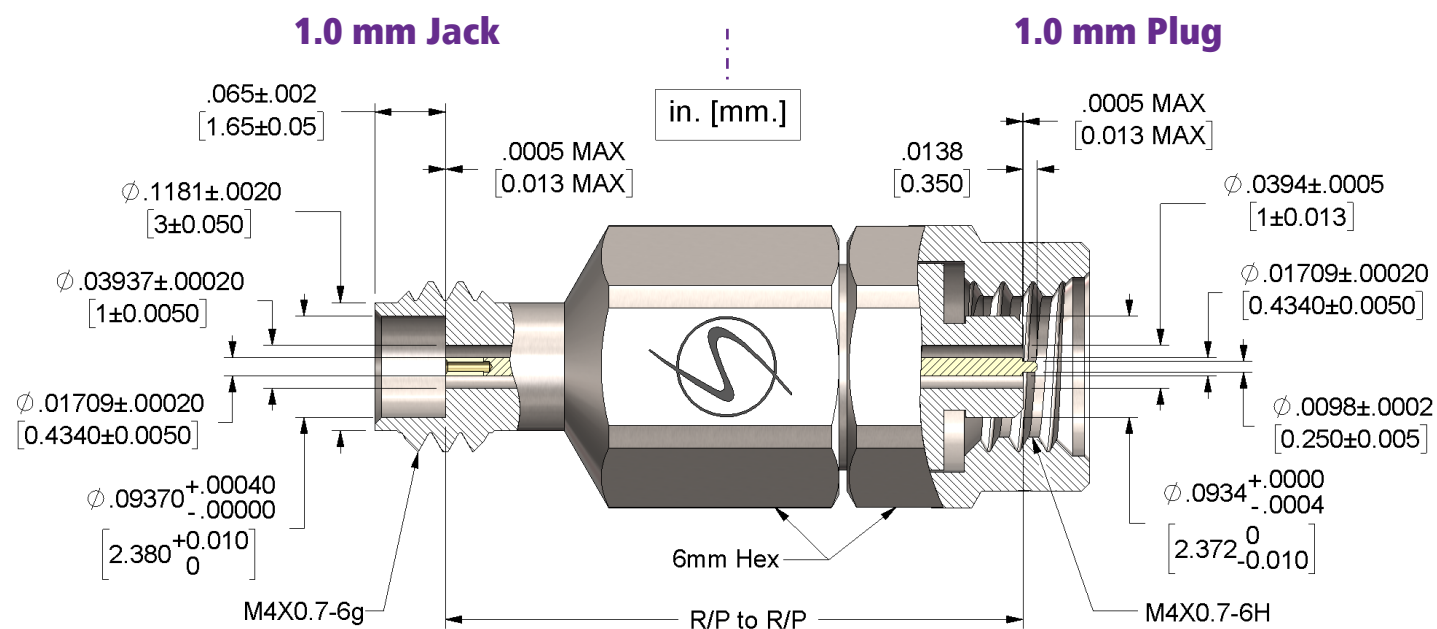

Component	Material	Finish
Contacts :	Beryllium Copper Per C17300	Gold Plated Per ASTM B- Type 2, Code C, 50-100 µin Thick Over Nickel Plated Per SAE-AMS-QQ-N-290, Class I. 50-100 µin Thick
Bodies :	Steel Corrosion Resistant, Non Magnetic ASTM-A-585 UNS NO. S30300	Passivated SEA - AMS - 2700 Method 1, Type 2
Insulators 1 :	Polyetherimide Resin General Electric Ultem 1000 ASTM D-5205	None
Insulators 2 :	Teflon, PTFE Per ASTM-D1710	None
Nuts :	Steel Corrosion Resistant, Non Magnetic ASTM-A-585 UNS NO. S30300	Passivated SEA - AMS - 2700 Method 1, Type 2
Snap-Rings :	Beryllium Copper Per C17300	Heat Treated



Precision Adapters

Description

1.0mm Plug - 1.0mm Plug

Part Number

CA-1111-01

Electrical

Frequency : DC – 110 GHz
VSWR : 1.28:1, Max
I.L. : 0.7 dB, Max

Mechanical

R/P to R/P : .534 [13.56]

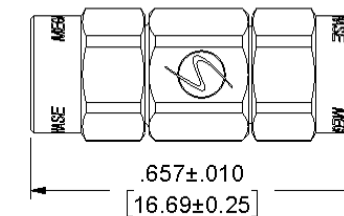

Description

1.0mm Jack - 1.0mm Plug

Part Number

CA-1112-01

Electrical

Frequency : DC – 110 GHz
VSWR : 1.28:1, Max
I.L. : 0.7 dB, Max

Mechanical

R/P to R/P : .534 [13.56]

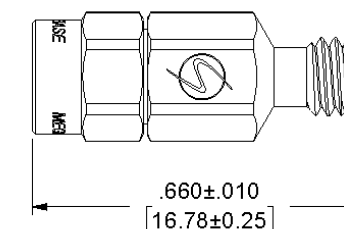

Description

1.0mm Jack - 1.0mm Jack

Part Number

CA-1212-01

Electrical

Frequency : DC – 110 GHz
VSWR : 1.28:1, Max
I.L. : 0.7 dB, Max

Mechanical

R/P to R/P : .534 [13.56]

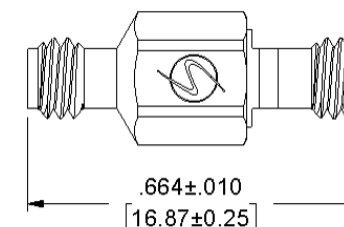



Precision Adapters

1.85 mm Interface

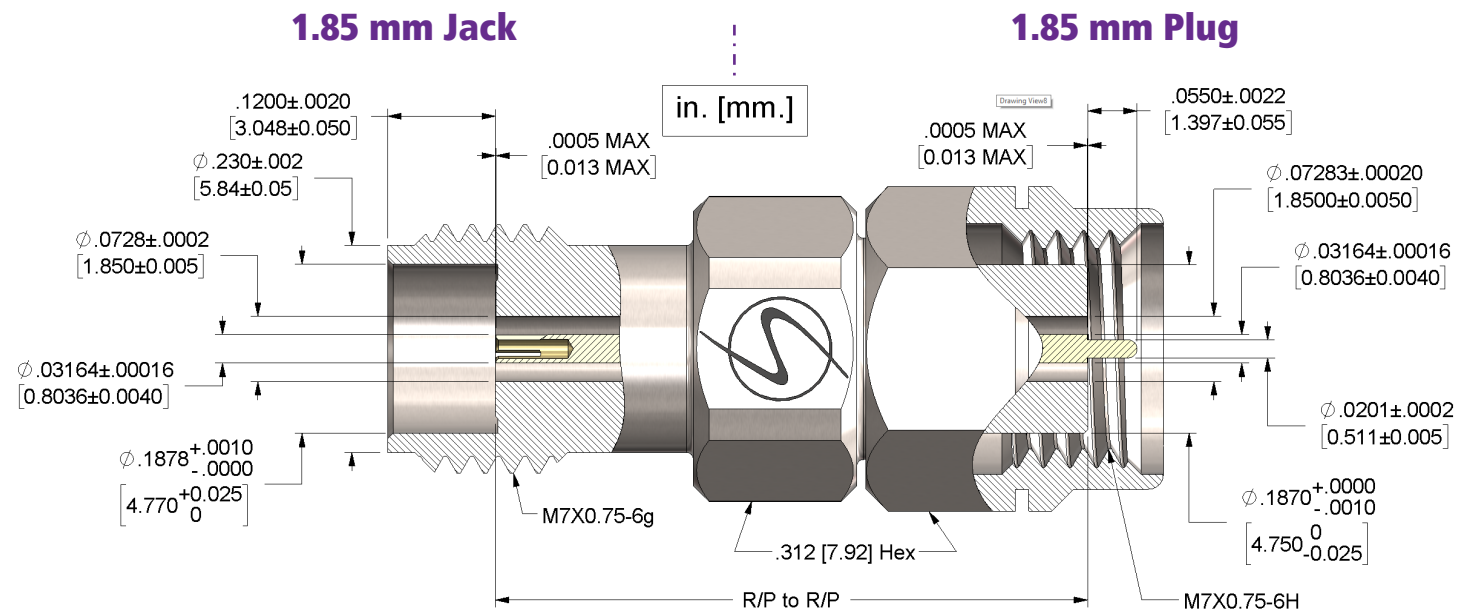

Component	Material	Finish
Contacts :	Beryllium Copper Per C17300	Gold Plated Per ASTM B- Type 2, Code C, 50-100 µin Thick Over Nickel Plated Per SAE-AMS-QQ-N-290, Class I. 50-100 µin Thick
Bodies :	Steel Corrosion Resistant, Non Magnetic ASTM-A-585 UNS NO. S30300	Passivated SEA - AMS - 2700 Method 1, Type 2
Insulators 1 :	Polyetherimide Resin General Electric Ultem 1000 ASTM D-5205	None
Insulators 2 :	Teflon, PTFE Per ASTM-D1710	None
Nuts :	Steel Corrosion Resistant, Non Magnetic ASTM-A-585 UNS NO. S30300	Passivated SEA - AMS - 2700 Method 1, Type 2
Snap-Rings :	Beryllium Copper Per C17300	Heat Treated



Precision Adapters

Description

1.85 mm Plug - 1.85 mm Plug

Part Number

CA-V1V1-01

Electrical

Frequency : DC – 65 GHz
VSWR : 1.28:1, Max
I.L. : 0.35 dB, Max

Mechanical

R/P to R/P : .659 [16.73]

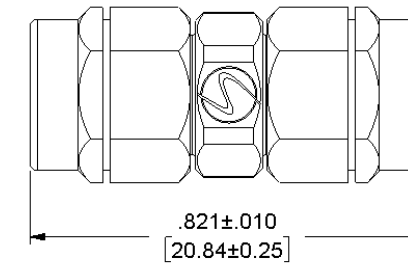

Description

1.85 mm Jack - 1.85 mm Plug

Part Number

CA-V1V2-01

Electrical

Frequency : DC – 65 GHz
VSWR : 1.28:1, Max
I.L. : 0.35 dB, Max

Mechanical

R/P to R/P : .659 [16.73]

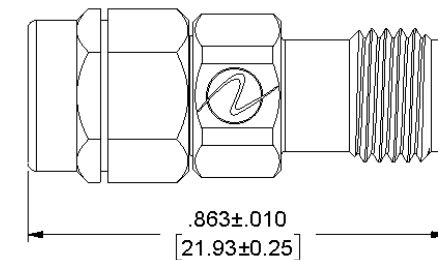

Description

1.85 mm Jack - 1.85 mm Jack

Part Number

CA-V2V2-01

Electrical

Frequency : DC – 65 GHz
VSWR : 1.28:1, Max
I.L. : 0.35 dB, Max

Mechanical

R/P to R/P : .659 [16.73]

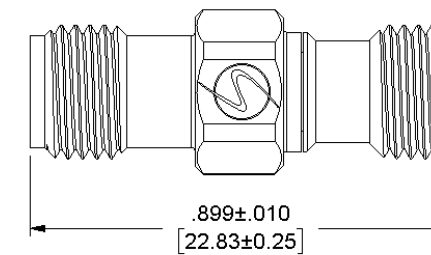



Precision Adapters

2.4 mm Interface

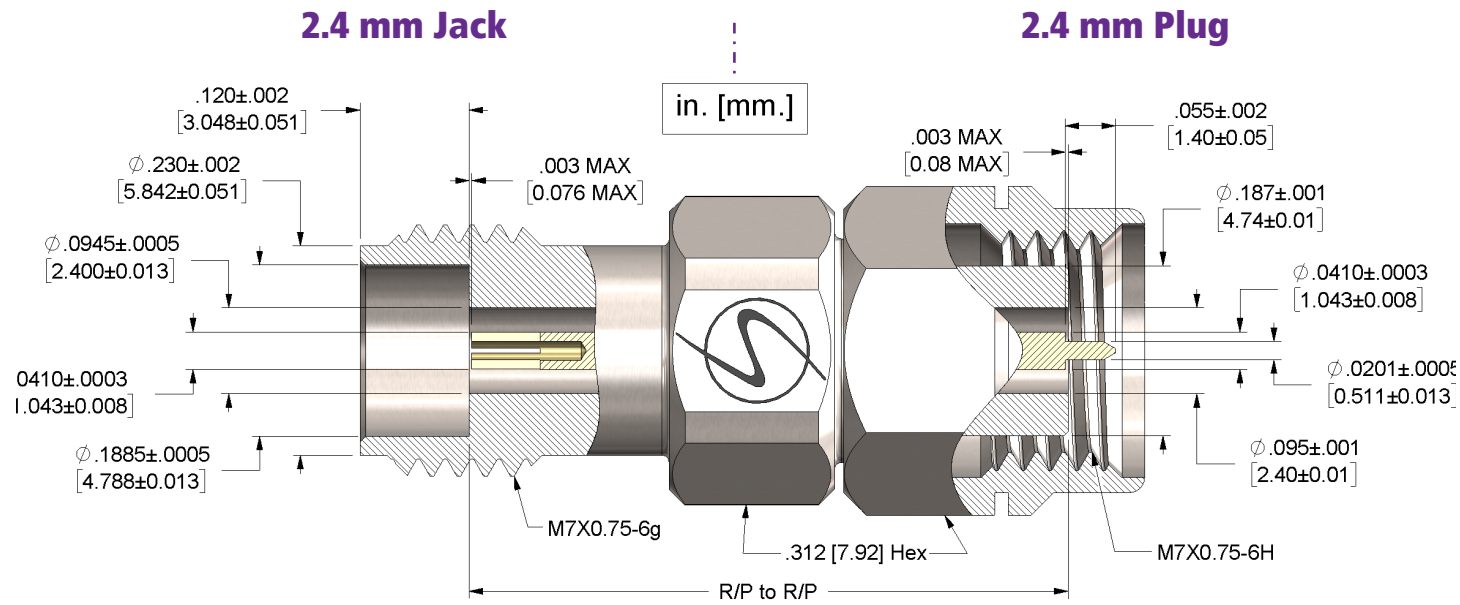

Component	Material	Finish
Contacts :	Beryllium Copper Per C17300	Gold Plated Per ASTM B- Type 2, Code C, 50-100 µin Thick Over Nickel Plated Per SAE-AMS-QQ-N-290, Class I. 50-100 µin Thick
Bodies :	Steel Corrosion Resistant, Non Magnetic ASTM-A-585 UNS NO. S30300	Passivated SEA - AMS - 2700 Method 1, Type 2
Insulators 1 :	Polyetherimide Resin General Electric Ultem 1000 ASTM D-5205	None
Insulators 2 :	Teflon, PTFE Per ASTM-D1710	None
Nuts :	Steel Corrosion Resistant, Non Magnetic ASTM-A-585 UNS NO. S30300	Passivated SEA - AMS - 2700 Method 1, Type 2
Snap-Rings :	Beryllium Copper Per C17300	Heat Treated



Precision Adapters

Description

2.4 mm Plug- 2.4 mm Plug

Part Number

CA-2121-01

Electrical

Frequency : DC – 50 GHz

VSWR : 1.28:1, Max

I.L. : 0.3 dB, Max

Mechanical

R/P to R/P : .659 [16.73]

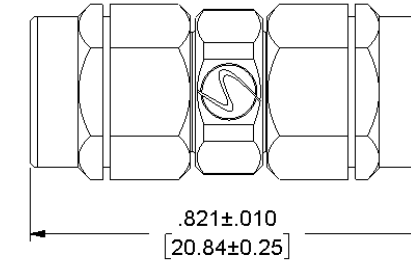

Description

2.4 mm Jack - 2.4 mm Plug

Part Number

CA-2122-01

Electrical

Frequency : DC – 50 GHz

VSWR : 1.28:1, Max

I.L. : 0.3 dB, Max

Mechanical

R/P to R/P : .659 [16.73]

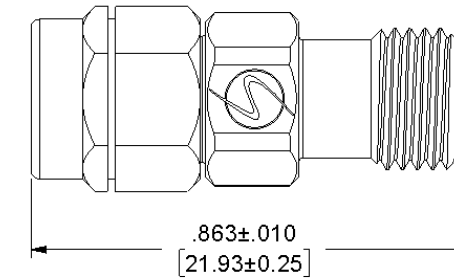

Description

2.4 mm Jack - 2.4 mm Jack

Part Number

CA-2222-01

Electrical

Frequency : DC – 50 GHz

VSWR : 1.28:1, Max

I.L. : 0.3 dB, Max

Mechanical

R/P to R/P : .659 [16.73]

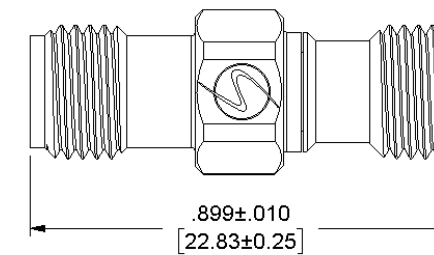



Precision Adapters

2.92 mm Interface

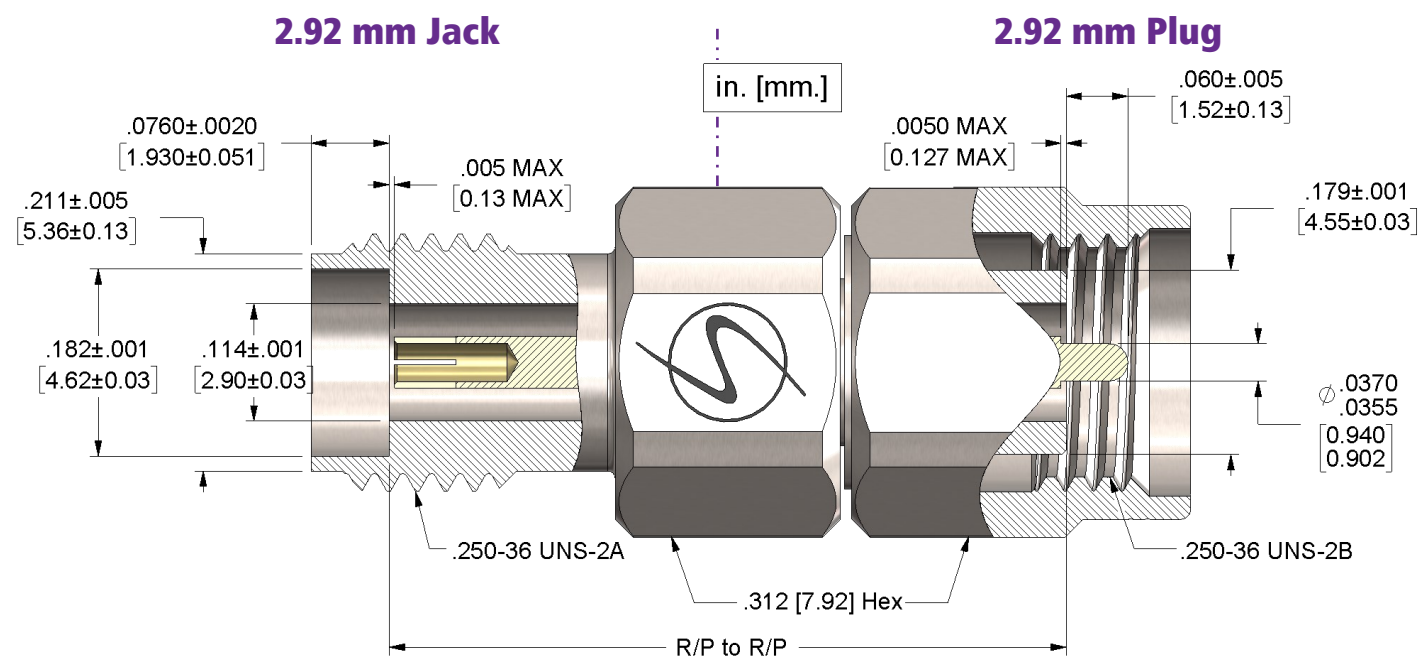

Component	Material	Finish
Contacts :	Beryllium Copper Per C17300	Gold Plated Per ASTM B- Type 2, Code C, 50-100 µin Thick Over Nickel Plated Per SAE-AMS-QQ-N-290, Class I. 50-100 µin Thick
Bodies :	Steel Corrosion Resistant, Non Magnetic ASTM-A-585 UNS NO. S30300	Passivated SEA - AMS - 2700 Method 1, Type 2
Insulators 1 :	Polyetherimide Resin General Electric Ultem 1000 ASTM D-5205	None
Insulators 2 :	Teflon, PTFE Per ASTM-D1710	None
Nuts :	Steel Corrosion Resistant, Non Magnetic ASTM-A-585 UNS NO. S30300	Passivated SEA - AMS - 2700 Method 1, Type 2
Snap-Rings :	Beryllium Copper Per C17300	Heat Treated



Precision Adapters

Description

2.92 mm Plug - 2.92 mm Plug

Part Number

CA-K1K1-01

Electrical

Frequency : DC – 40 GHz
VSWR : 1.20:1, Max
I.L. : 0.25dB, Max

Mechanical

R/P to R/P : .659 [16.73]

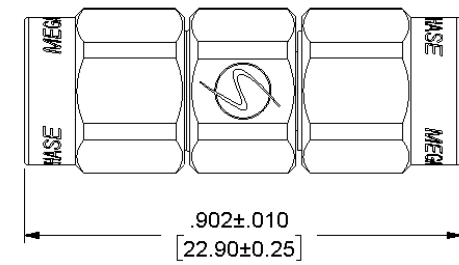

Description

2.92 mm Jack - 2.92 mm Plug

Part Number

CA-K1K2-01

Electrical

Frequency : DC – 40 GHz
VSWR : 1.20:1, Max
I.L. : 0.25 dB, Max

Mechanical

R/P to R/P : .659 [16.73]

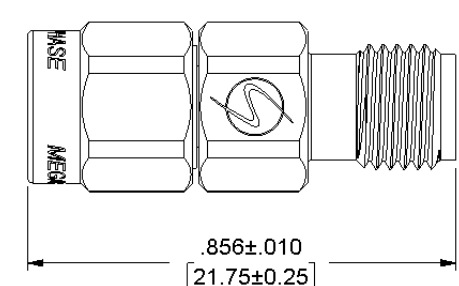

Description

2.92 mm Jack - 2.92 mm Jack

Part Number

CA-K2K2-01

Electrical

Frequency : DC – 40 GHz
VSWR : 1.20:1, Max
I.L. : 0.25 dB, Max

Mechanical

R/P to R/P : .659 [16.73]

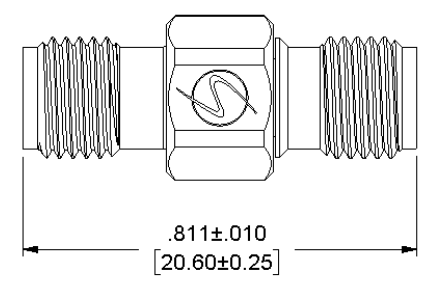



Precision Adapters

SMPM Interface

SMPM Female

SMPM Male

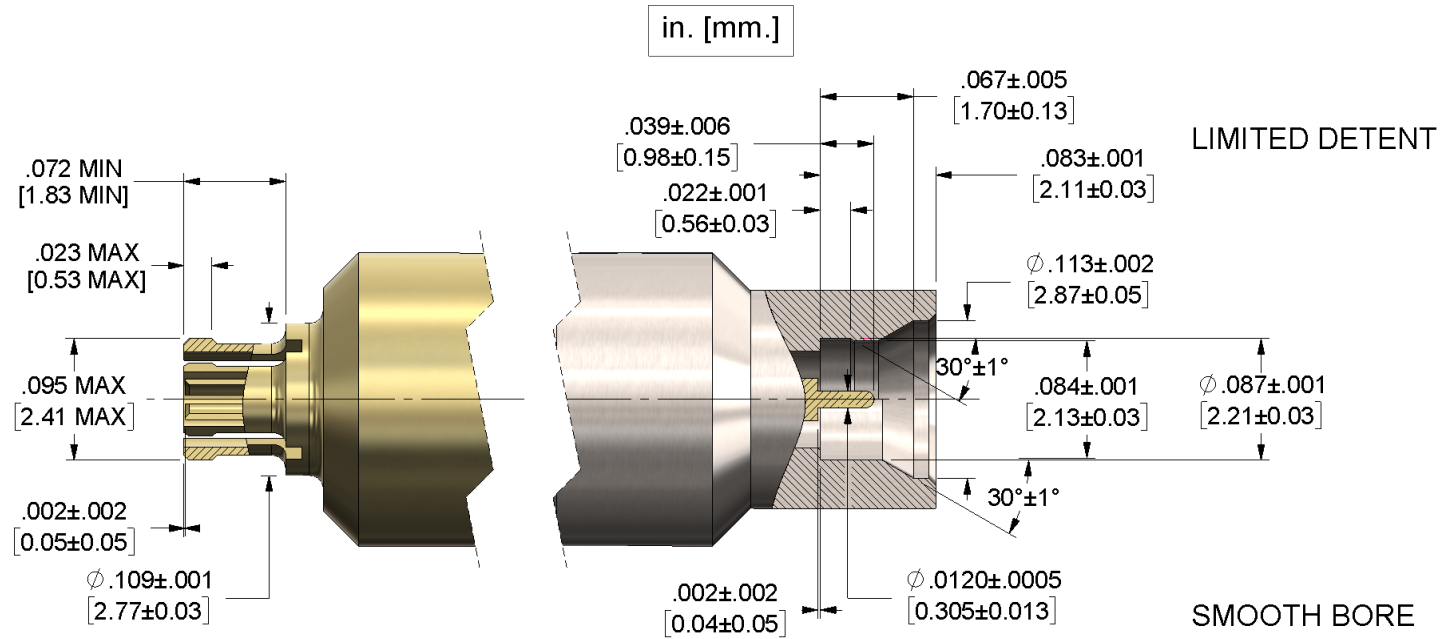

Component	Material	Finish
Contacts :	Beryllium Copper Per C17300	Gold Plated Per ASTM B- Type 2, Code C, 50-100 μin Thick Over Nickel Plated Per SAE-AMS-QQ-N-290, Class I. 50-100 μin Thick
Bodies 1 :	Beryllium Copper Per C17300	Gold Plated Per ASTM B- Type 2, Code C, 50-100 μin Thick Over Nickel Plated Per SAE-AMS-QQ-N-290, Class I. 50-100 μin Thick
Bodies 2 :	Steel Corrosion Resistant, Non Magnetic ASTM-A-585 UNS NO. S30300	Passivated SEA - AMS - 2700 Method 1, Type 2
Insulators :	Teflon, PTFE Per ASTM-D1710	None
Nuts :	Steel Corrosion Resistant, Non Magnetic ASTM-A-585 UNS NO. S30300	Passivated SEA - AMS - 2700 Method 1, Type 2
Snap-Rings :	Beryllium Copper Per C17300	Heat Treated



Precision Adapters

Description

SMPM Male - 1.85mm Plug

Part Number

CA-GS1V1-01

Electrical

Frequency : DC – 65 GHz
 VSWR : 1.35:1, Max
 I.L. : 0.35 dB, Max

Mechanical

R/P to R/P : .659 [16.73]

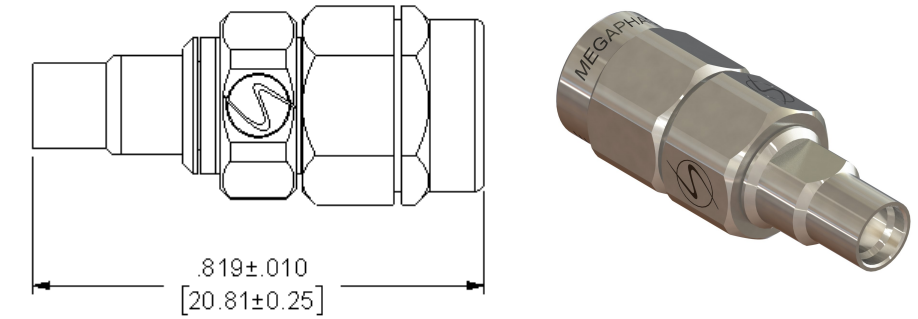

Description

SMPM Male - 1.85mm Jack

Part Number

CA-GS1V2-01

Electrical

Frequency : DC – 65 GHz
 VSWR : 1.35:1, Max
 I.L. : 0.35 dB, Max

Mechanical

R/P to R/P : .659 [16.73]

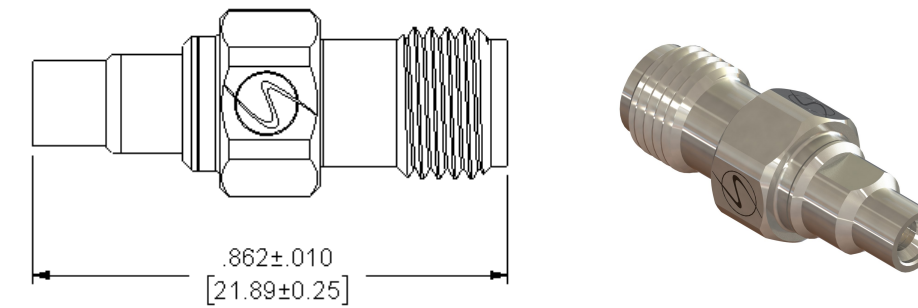

Description

SMPM Female - 1.85mm Plug

Part Number

CA-GS2V1-01

Electrical

Frequency : DC – 65 GHz
 VSWR : 1.35:1, Max
 I.L. : 0.35 dB, Max

Mechanical

R/P to R/P : .659 [16.73]

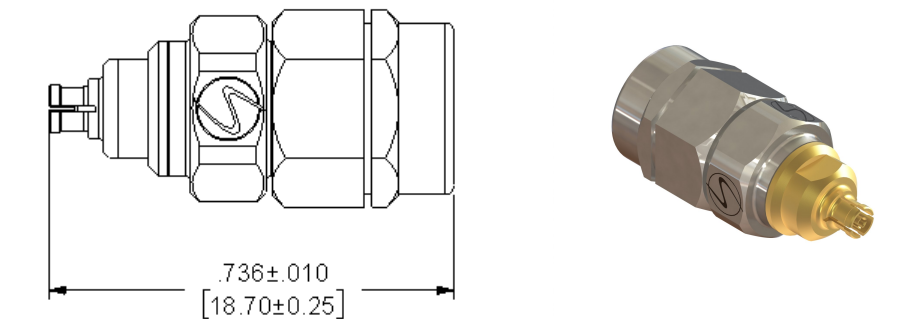

Description

SMPM Female - 1.85mm Jack

Part Number

CA-GS2V2-01

Electrical

Frequency : DC – 65 GHz
 VSWR : 1.35:1, Max
 I.L. : 0.35 dB, Max

Mechanical

R/P to R/P : .659 [16.73]

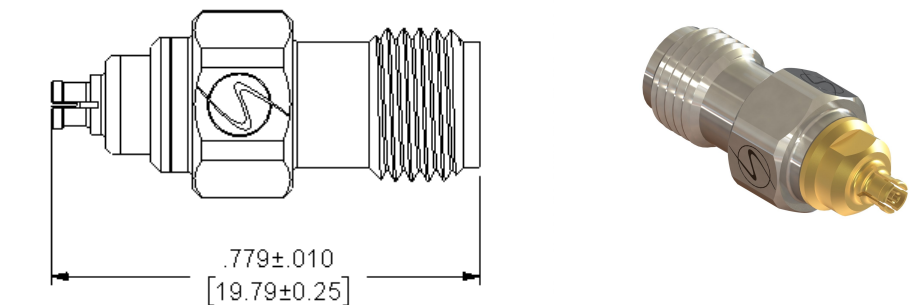



Precision Adapters

SMP Interface

SMP Male

SMP Female

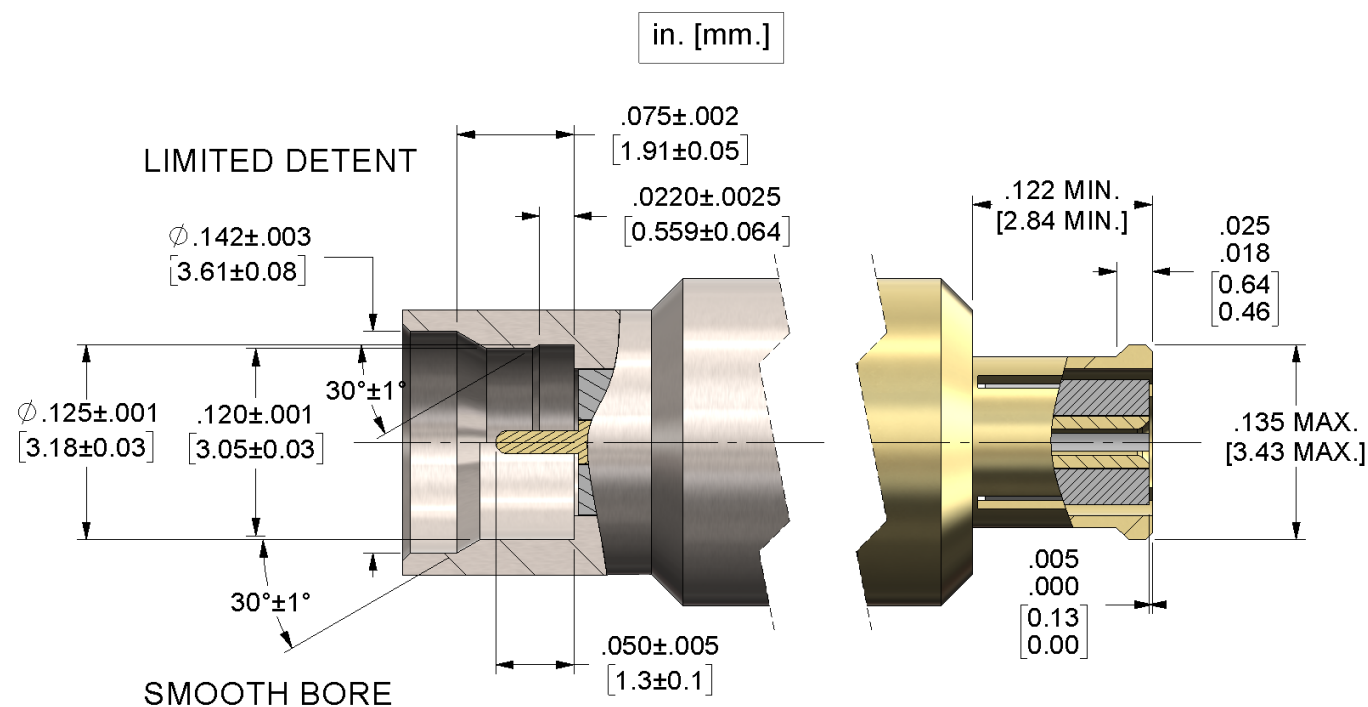

Component	Material	Finish
Contacts :	Beryllium Copper Per C17300	Gold Plated Per ASTM B- Type 2, Code C, 50-100 μ m Thick Over Nickel Plated Per SAE-AMS-QQ-N-290, Class I. 50-100 μ m Thick
Bodies 1 :	Beryllium Copper Per C17300	Gold Plated Per ASTM B- Type 2, Code C, 50-100 μ m Thick Over Nickel Plated Per SAE-AMS-QQ-N-290, Class I. 50-100 μ m Thick
Bodies 2 :	Steel Corrosion Resistant, Non Magnetic ASTM-A-585 UNS NO. S30300	Passivated SEA - AMS - 2700 Method 1, Type 2
Insulators :	Teflon, PTFE Per ASTM-D1710	None
Nuts :	Steel Corrosion Resistant, Non Magnetic ASTM-A-585 UNS NO. S30300	Passivated SEA - AMS - 2700 Method 1, Type 2
Snap-Rings :	Beryllium Copper Per C17300	Heat Treated
Anti-Rock Ring	Beryllium Copper Per C17300	Gold Plated Per ASTM B- Type 2, Code C, 50-100 μ m Thick Over Nickel Plated Per SAE-AMS-QQ-N-290, Class I. 50-100 μ m Thick



Precision Adapters

Description

SMP Male - 2.92 mm Plug

Part Number

CA-G1K1-01

Electrical

Frequency : DC – 40 GHz
VSWR : 1.20:1, Max
I.L. : 0.25 dB, Max

Mechanical

R/P to R/P : .659 [16.73]

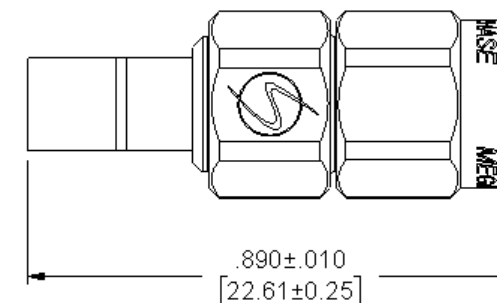

Description

SMP Male - 2.92 mm Jack

Part Number

CA-G1K2-01

Electrical

Frequency : DC – 40 GHz
VSWR : 1.20:1, Max
I.L. : 0.25 dB, Max

Mechanical

R/P to R/P : .659 [16.73]

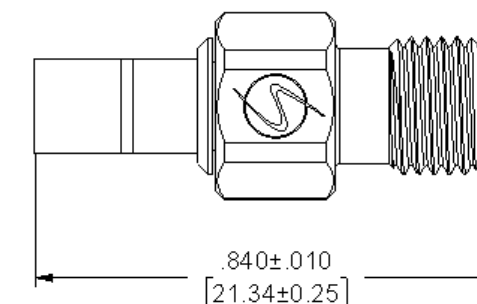

Description

SMP Female - 2.92 mm Plug

Part Number

CA-G2K1-01

Electrical

Frequency : DC – 40 GHz
VSWR : 1.20:1, Max
I.L. : 0.25 dB, Max

Mechanical

R/P to R/P : .659 [16.73]

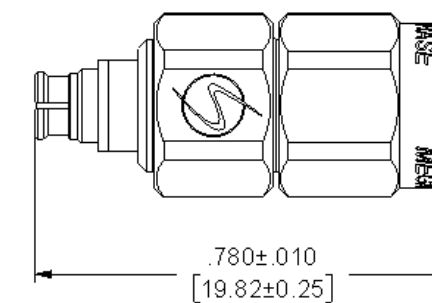

Description

SMP Female - 2.92 mm Jack

Part Number

CA-G2K2-01

Electrical

Frequency : DC – 40 GHz
VSWR : 1.20:1, Max
I.L. : 0.25 dB, Max

Mechanical

R/P to R/P : .659 [16.73]

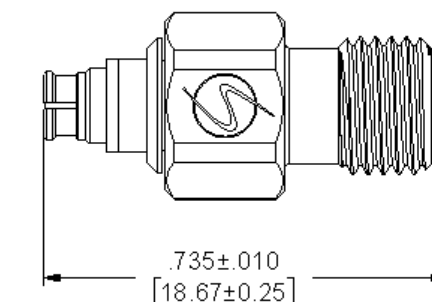



Precision Adapters

Description

1.0mm Plug - 1.85mm Plug

Part Number

CA-11V1-01

Electrical

Frequency : DC – 65 GHz

VSWR : 1.35:1, Max

I.L. : 0.35 dB, Max

Mechanical

R/P to R/P : .659 [16.73]

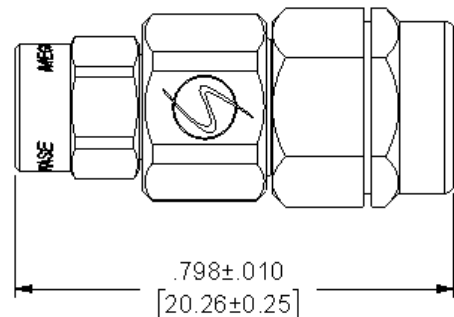

Description

1.0mm Plug - 1.85mm Jack

Part Number

CA-11V2-01

Electrical

Frequency : DC – 65 GHz

VSWR : 1.35:1, Max

I.L. : 0.35 dB, Max

Mechanical

R/P to R/P : .659 [16.73]

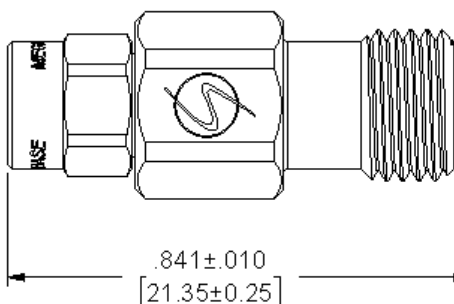

Description

1.0mm Jack - 1.85mm Plug

Part Number

CA-12V1-01

Electrical

Frequency : DC – 65 GHz

VSWR : 1.35:1, Max

I.L. : 0.35 dB, Max

Mechanical

R/P to R/P : .659 [16.73]

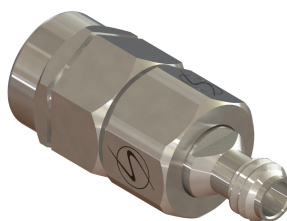
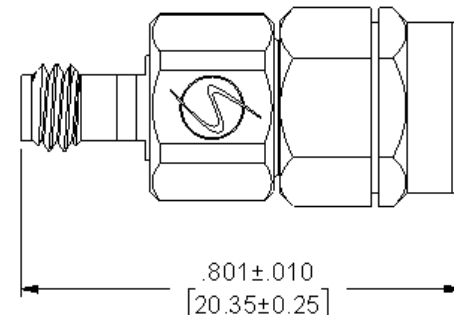

Description

1.0mm Jack - 1.85mm Jack

Part Number

CA-12V2-01

Electrical

Frequency : DC – 65 GHz

VSWR : 1.35:1, Max

I.L. : 0.35 dB, Max

Mechanical

R/P to R/P : .659 [16.73]

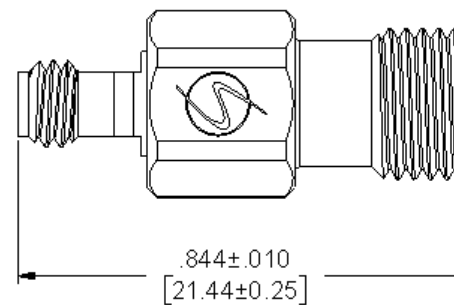

Precision Adapters

Description

1.85mm Plug - 2.4mm Plug

Part Number

CA-21V1-01

Electrical

Frequency : DC – 50 GHz

VSWR : 1.28:1, Max

I.L. : 0.3 dB, Max

Mechanical

R/P to R/P : .659 [16.73]

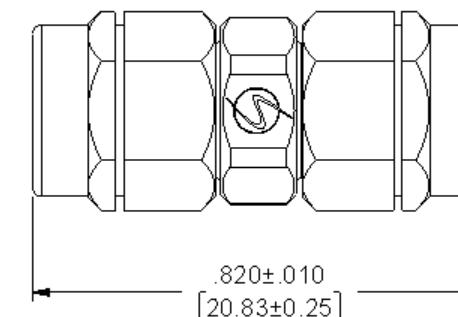

Description

1.85mm Jack - 2.4mm Plug

Part Number

CA-21V2-01

Electrical

Frequency : DC – 50 GHz

VSWR : 1.28:1, Max

I.L. : 0.3 dB, Max

Mechanical

R/P to R/P : .659 [16.73]

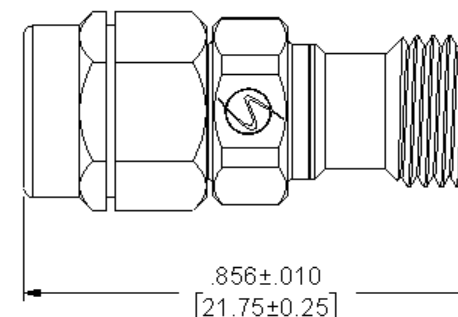

Description

1.85mm Plug - 2.4mm Jack

Part Number

CA-22V1-01

Electrical

Frequency : DC – 50 GHz

VSWR : 1.28:1, Max

I.L. : 0.3 dB, Max

Mechanical

R/P to R/P : .659 [16.73]

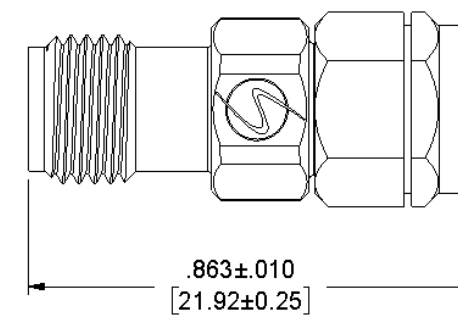

Description

1.85mm Jack - 2.4mm Jack

Part Number

CA-22V2-01

Electrical

Frequency : DC – 50 GHz

VSWR : 1.28:1, Max

I.L. : 0.3 dB, Max

Mechanical

R/P to R/P : .659 [16.73]

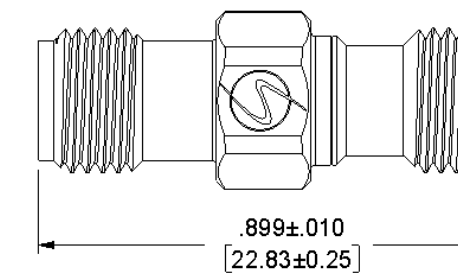



Precision Adapters

Description

2.4mm Jack - 2.92 mm Jack

Part Number

CA-21K1-01

Electrical

Frequency : DC – 40 GHz

VSWR : 1.28:1, Max

I.L. : 0.3 dB, Max

Mechanical

R/P to R/P : .659 [16.73]

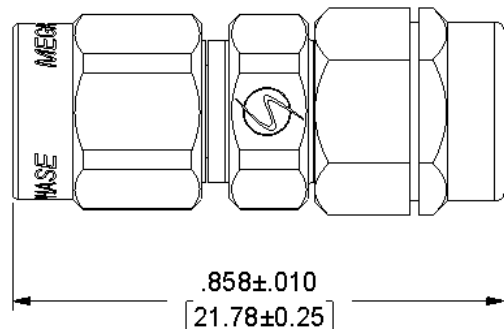

Description

2.4mm Jack - 2.92 mm Plug

Part Number

CA-21K2-01

Electrical

Frequency : DC – 40 GHz

VSWR : 1.28:1, Max

I.L. : 0.3 dB, Max

Mechanical

R/P to R/P : .659 [16.73]

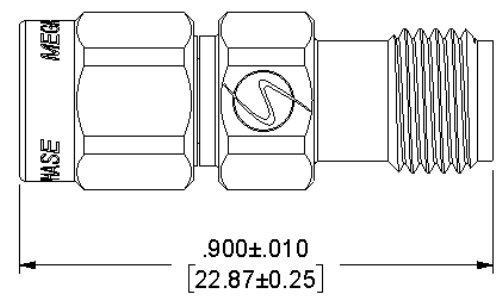

Description

2.4mm Jack - 2.92 mm Plug

Part Number

CA-22K1-01

Electrical

Frequency : DC – 40 GHz

VSWR : 1.28:1, Max

I.L. : 0.3 dB, Max

Mechanical

R/P to R/P : .659 [16.73]

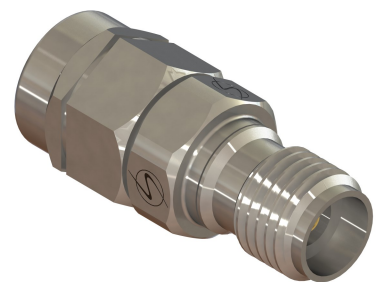
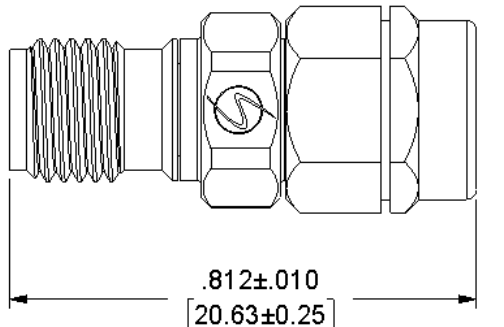

Description

2.4mm Jack - 2.92 mm Plug

Part Number

CA-22K2-01

Electrical

Frequency : DC – 40 GHz

VSWR : 1.28:1, Max

I.L. : 0.3 dB, Max

Mechanical

R/P to R/P : .659 [16.73]

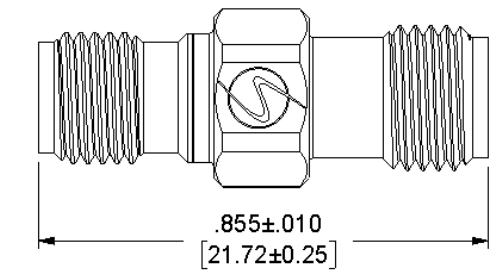

CABLE CONNECTORS

Root Of The Connection

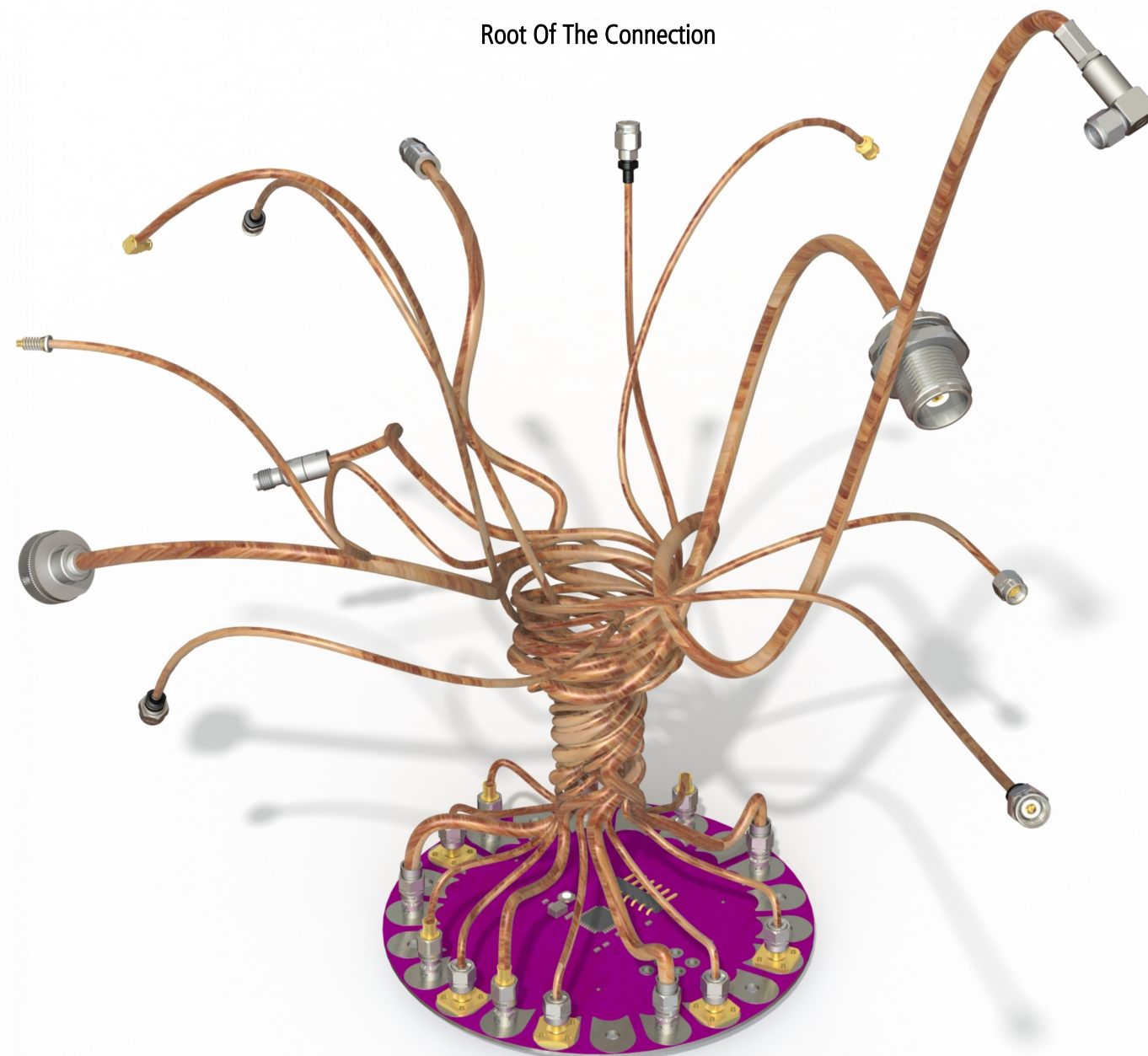



Cable Connectors

SMP3/SMPS Interface

SMP3 Female

SMP3 Male

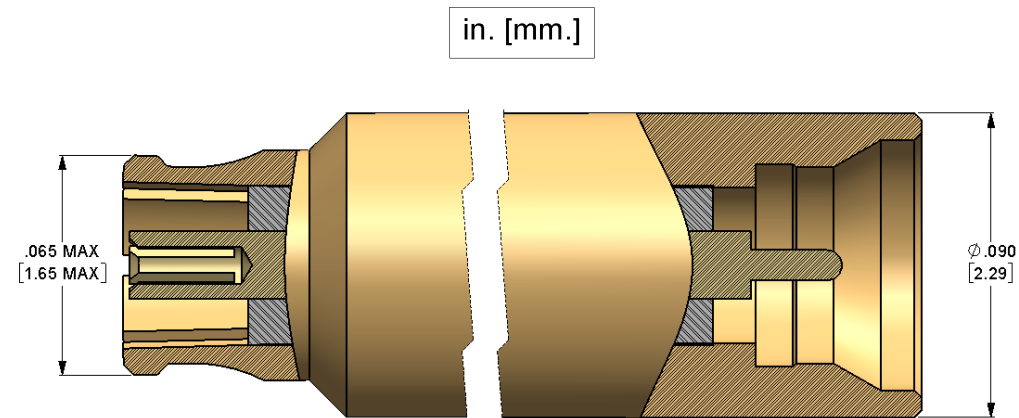

Component	Material	Finish
Contacts :	Beryllium Copper Per C17300	Gold Plated Per ASTM B- Type 2, Code C, 50-100 μin Thick Over Nickel Plated Per SAE-AMS-QQ-N-290, Class I. 50-100 μin Thick
Bodies :	Beryllium Copper Per C17300	Gold Plated Per ASTM B- Type 2, Code C, 50-100 μin Thick Over Nickel Plated Per SAE-AMS-QQ-N-290, Class I. 50-100 μin Thick
Insulators :	Teflon, PTFE Per ASTM-D1710	None
Nuts :	Steel Corrosion Resistant, Non Magnetic ASTM-A-585 UNS NO. S30300	Passivated SEA - AMS - 2700 Method 1, Type 2



Cable Connectors

Description

SMP3 Male for .047 Cable

Part Number

CN-G31-047-01

Electrical

Frequency : DC – 70 GHz

VSWR : 1.30:1, Max

I.L. : 0.35 dB, Max

Mechanical

Interface Detent : F.D. , S.B.

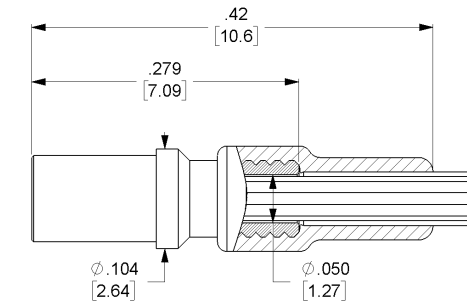

Description

SMP3 Female for .047 Cable

Part Number

CN-G32-047-01

Electrical

Frequency : DC – 70 GHz

VSWR : 1.30:1, Max

I.L. : 0.35 dB, Max

Mechanical

N/A

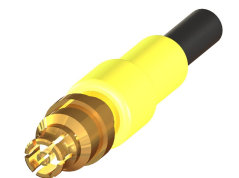
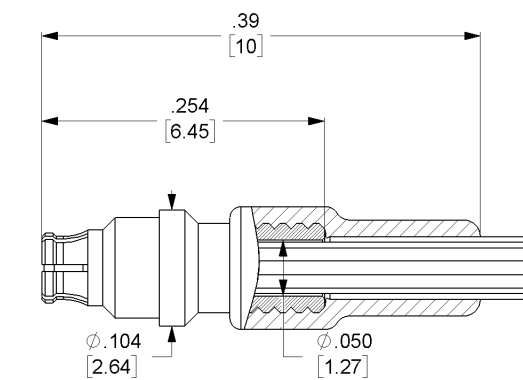

Description

SMP3 Male for .047 Cable

Part Number

CN-G3C-047-01

Electrical

Frequency : DC – 70 GHz

VSWR : 1.30:1, Max

I.L. : 0.35 dB, Max

Mechanical

Interface Detent : F.D. , S.B.

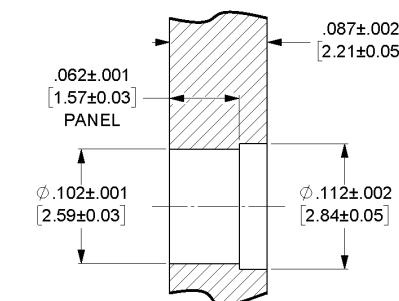
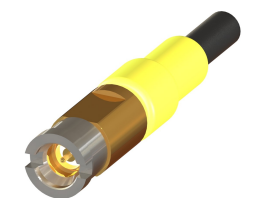
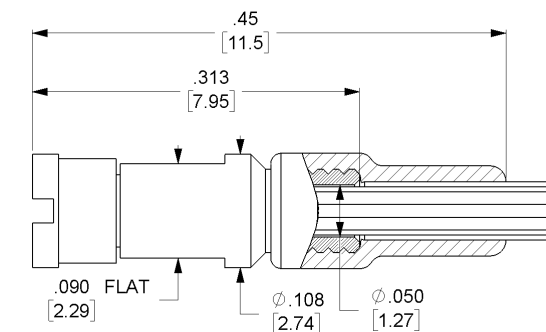



Cable Connectors

SMP3/SMPS Gang Connector

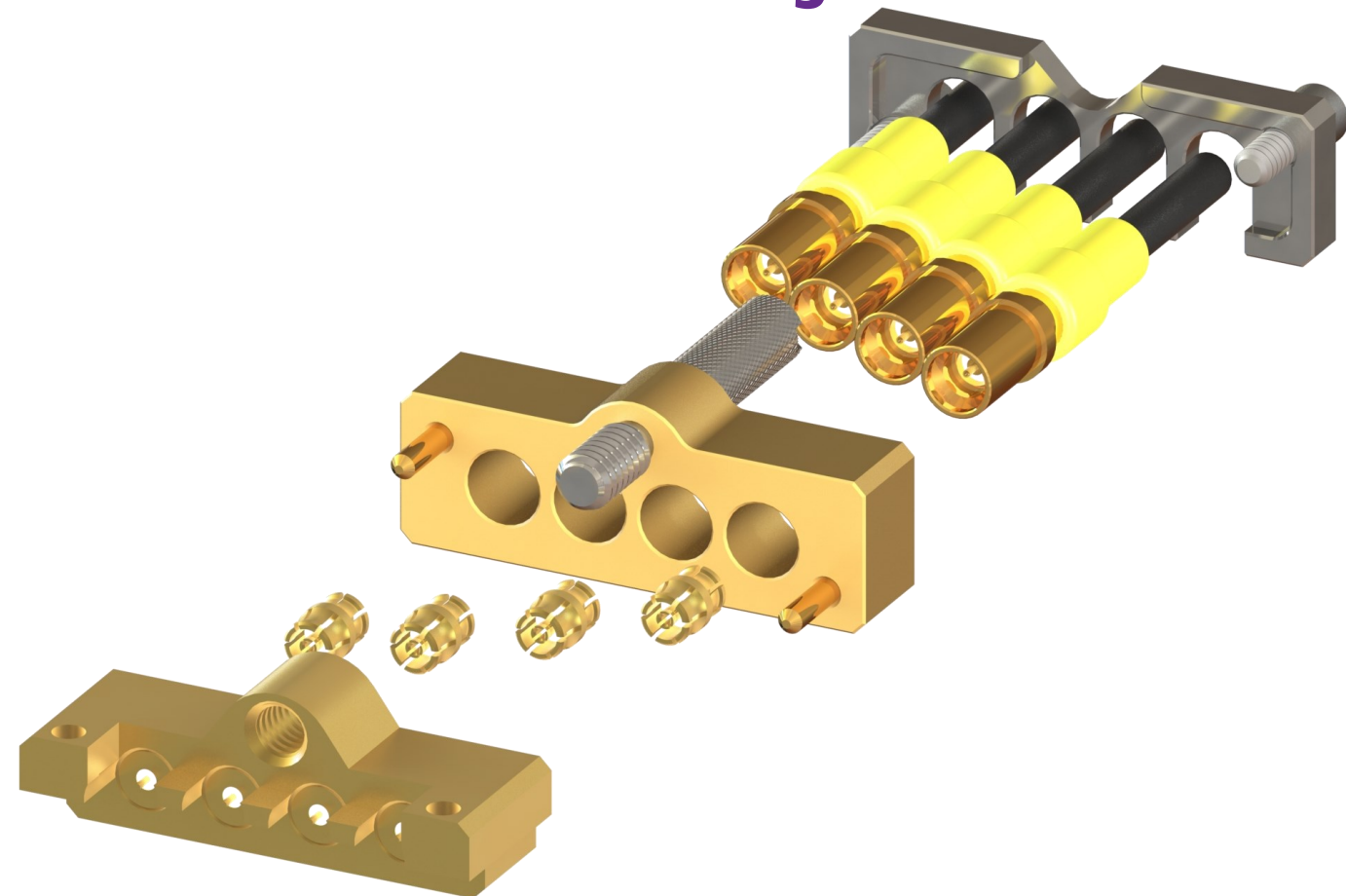

Component	Material	Finish
Cable connector : See : CN-G31-047-01		
Contacts :	Beryllium Copper Per C17300	Gold Plated Per ASTM B- Type 2, Code C, 50-100 μin Thick Over Nickel Plated Per SAE-AMS-QQ-N-290, Class I. 50-100 μin Thick
Bodies :	Beryllium Copper Per C17300	Gold Plated Per ASTM B- Type 2, Code C, 50-100 μin Thick Over Nickel Plated Per SAE-AMS-QQ-N-290, Class I. 50-100 μin Thick
Insulators :	Teflon, PTFE Per ASTM-D1710	None
Nuts :	Steel Corrosion Resistant, Non Magnetic ASTM-A-585 UNS NO. S30300	Passivated SEA - AMS - 2700 Method 1, Type 2
Pins :	Beryllium Copper Per C17300	Gold Plated Per ASTM B- Type 2, Code C, 50-100 μin Thick Over Nickel Plated Per SAE-AMS-QQ-N-290, Class I. 50-100 μin Thick
Screws :	Steel Corrosion Resistant, Non Magnetic ASTM-A-585 UNS NO. S30300	Passivated SEA - AMS - 2700 Method 1, Type 2
Retaining Plate :	Steel Corrosion Resistant, Non Magnetic ASTM-A-585 UNS NO. S30300	Passivated SEA - AMS - 2700 Method 1, Type 2



Cable Connectors

Description

SMP3 Male for PCB

Part Number

CB-G3E1-04-01A

Electrical

Frequency : DC – 70 GHz

Mechanical

Interface Detent : F.D. , S.B.

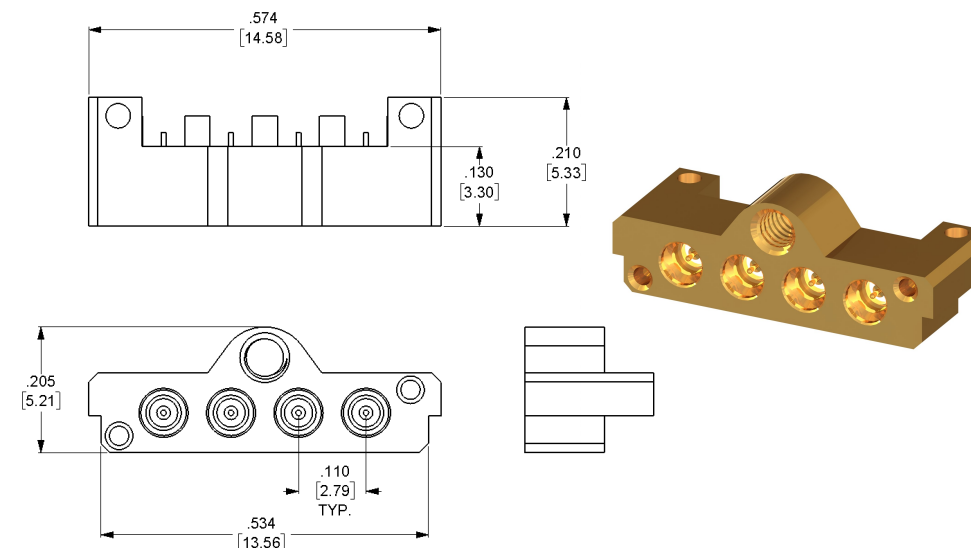

Description

Shell for SMP3 Male .047 Cable

Part Number

CB-G31-04-01B

Electrical

N/A

Mechanical

N/A

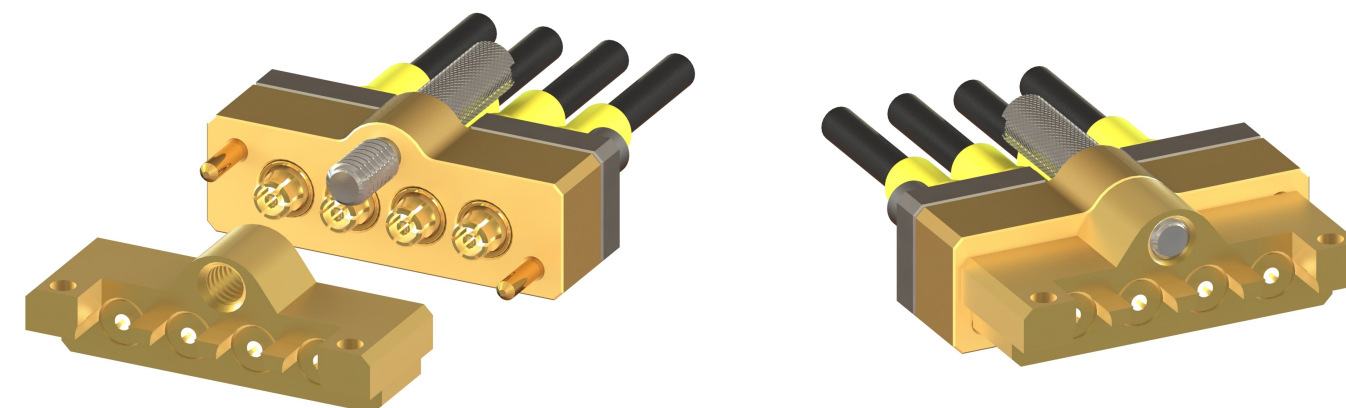
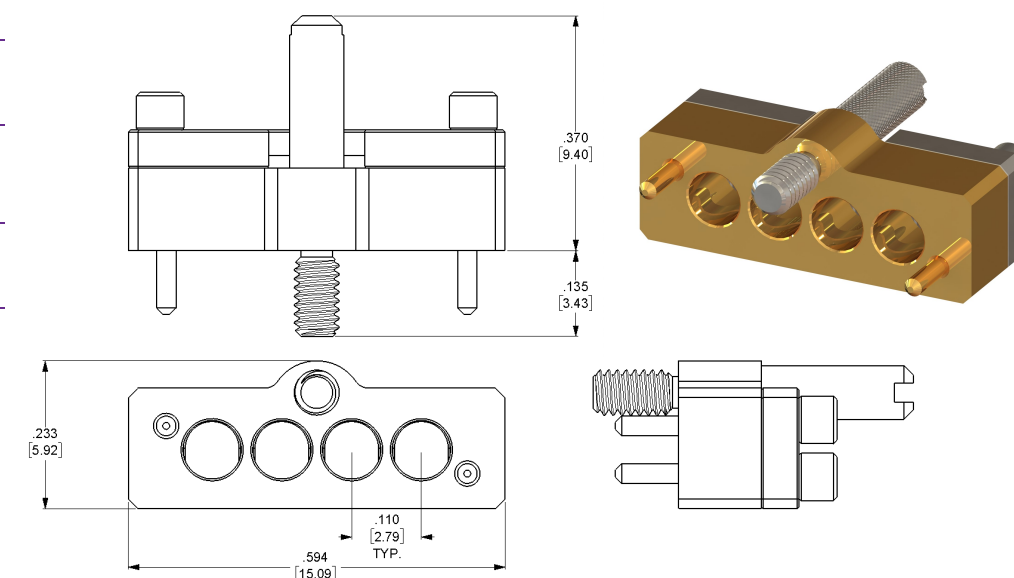



Cable Connectors

1.85 mm Interface

1.85 mm Jack

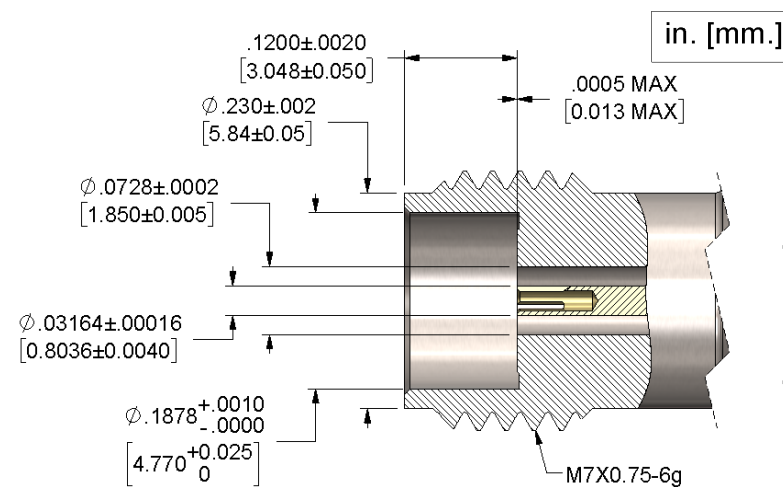

1.85 mm Plug

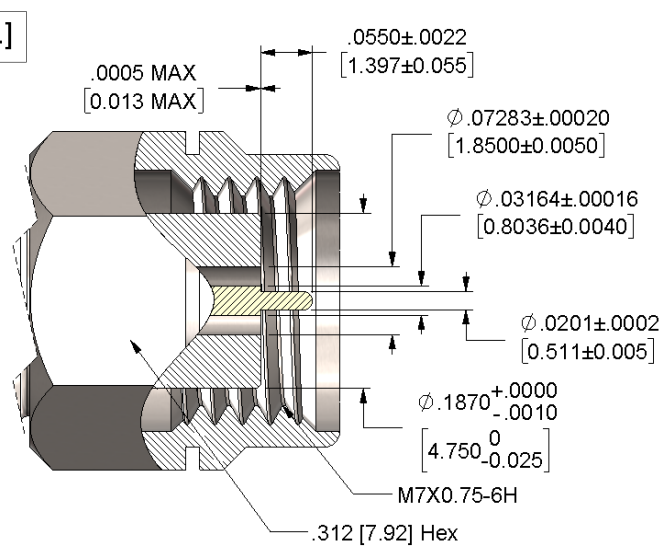

Component	Material	Finish
Contacts :	Beryllium Copper Per C17300	Gold Plated Per ASTM B- Type 2, Code C, 50-100 µin Thick Over Nickel Plated Per SAE-AMS-QQ-N-290, Class I. 50-100 µin Thick
Bodies :	Steel Corrosion Resistant, Non Magnetic ASTM-A-585 UNS NO. S30300	Passivated SEA - AMS - 2700 Method 1, Type 2
Insulators 1 :	Polyetherimide Resin General Electric Ultem 1000 ASTM D-5205	None
Insulators 2 :	Teflon, PTFE Per ASTM-D1710	None
Solder Adaptors :	Steel Corrosion Resistant, Non Magnetic ASTM-A-585 UNS NO. S30300	Gold Plated Per ASTM B- Type 2, Code C, 50-100 µin Thick Over Nickel Plated Per SAE-AMS-QQ-N-290, Class I. 50-100 µin Thick
Nuts :	Steel Corrosion Resistant, Non Magnetic ASTM-A-585 UNS NO. S30300	Passivated SEA - AMS - 2700 Method 1, Type 2
Snap-Rings :	Beryllium Copper Per C17300	Heat Treated



Cable Connectors

Description

1.85 mm Plug for .047 Cable

Part Number

CN11-047-01

Electrical

Frequency : DC – 65 GHz

VSWR : 1.35:1, Max

I.L. : 0.35 dB, Max

Mechanical

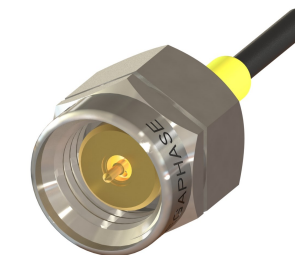
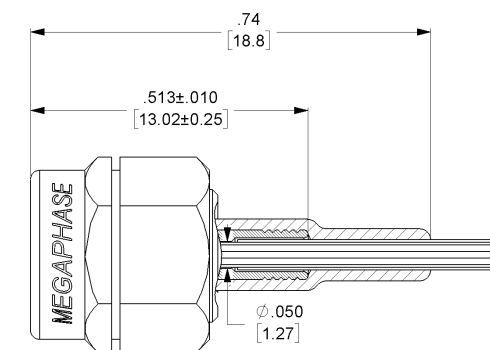

Description

1.85 mm Plug for .047 Cable

Part Number

CN12-047-01

Electrical

Frequency : DC – 65 GHz

VSWR : 1.35:1, Max

I.L. : 0.35 dB, Max

Mechanical

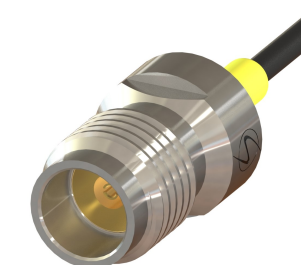
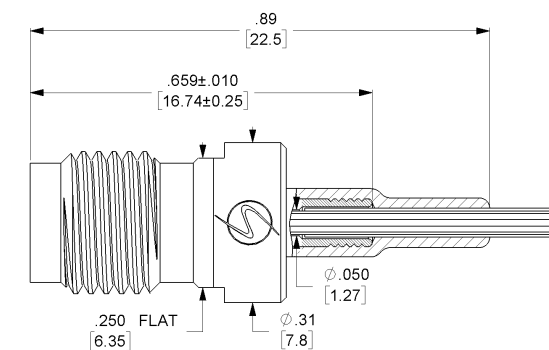



Cable Connectors

2.4 mm Interface

2.4 mm Jack

2.4 mm Plug

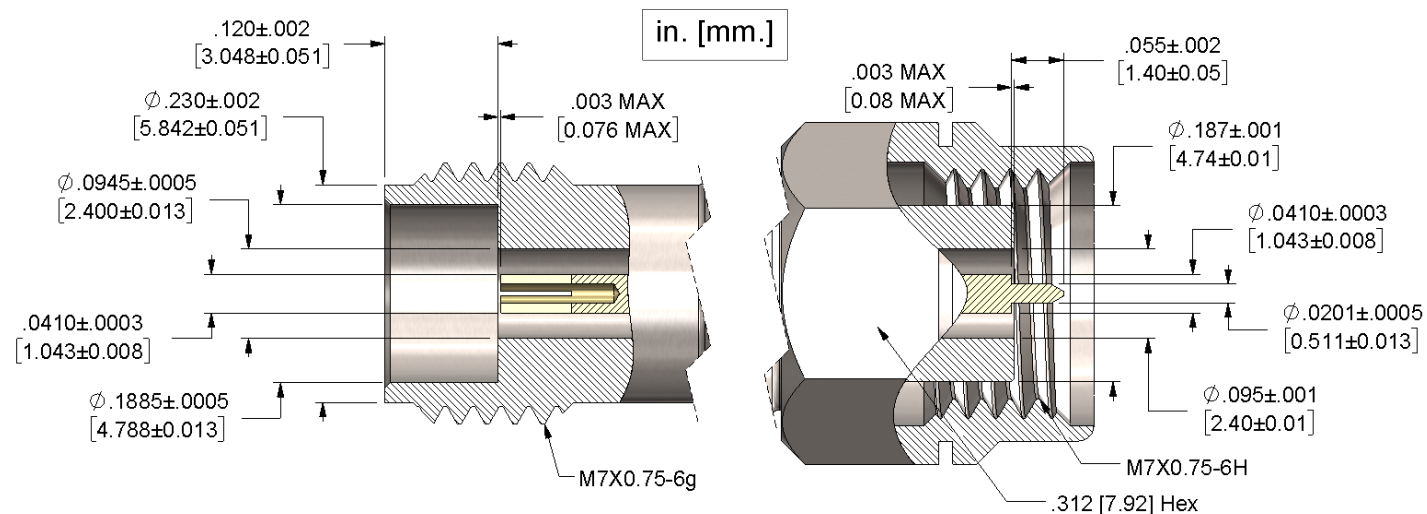

Component	Material	Finish
Contacts :	Beryllium Copper Per C17300	Gold Plated Per ASTM B- Type 2, Code C, 50-100 μ m Thick Over Nickel Plated Per SAE-AMS-QQ-N-290, Class I. 50-100 μ m Thick
Bodies :	Steel Corrosion Resistant, Non Magnetic ASTM-A-585 UNS NO. S30300	Passivated SEA - AMS - 2700 Method 1, Type 2
Or Bodies :	Brass Per C36000, 1/2 Hard	Gold Plated Per ASTM B- Type 2, Code C, 50-100 μ m Thick Over Nickel Plated Per SAE-AMS-QQ-N-290, Class I. 50-100 μ m Thick
Insulators 1 :	Polyetherimide Resin General Electric Ultem 1000 ASTM D-5205	None
Insulators 2 :	Teflon, PTFE Per ASTM-D1710	None
Solder Adaptors :	Steel Corrosion Resistant, Non Magnetic ASTM-A-585 UNS NO. S30300	Gold Plated Per ASTM B- Type 2, Code C, 50-100 μ m Thick Over Nickel Plated Per SAE-AMS-QQ-N-290, Class I. 50-100 μ m Thick
Nuts :	Steel Corrosion Resistant, Non Magnetic ASTM-A-585 UNS NO. S30300	Passivated SEA - AMS - 2700 Method 1, Type 2
Snap-Rings :	Beryllium Copper Per C17300	Heat Treated



Cable Connectors

Description

2.4mm Jack for .086 Cable

Part Number

CN-21-086-01

Electrical

Frequency : DC – 50 GHz

VSWR : 1.35:1, Max

I.L. : 0.3 dB, Max

Mechanical

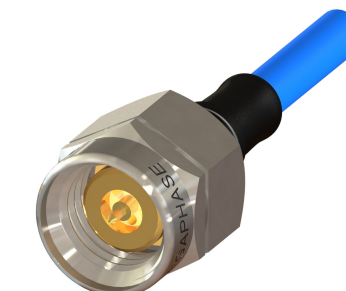
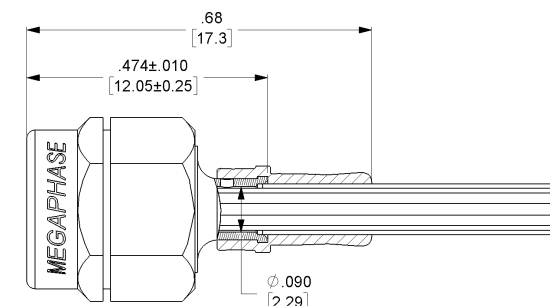

Description

2.4mm Plug for .086 Cable

Part Number

CN-22-086-01

Electrical

Frequency : DC – 50 GHz

VSWR : 1.35:1, Max

I.L. : 0.3 dB, Max

Mechanical

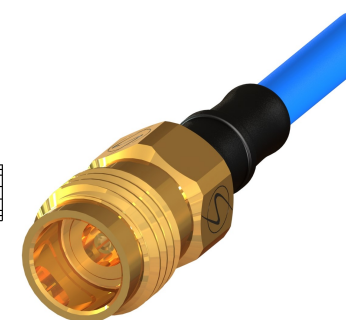
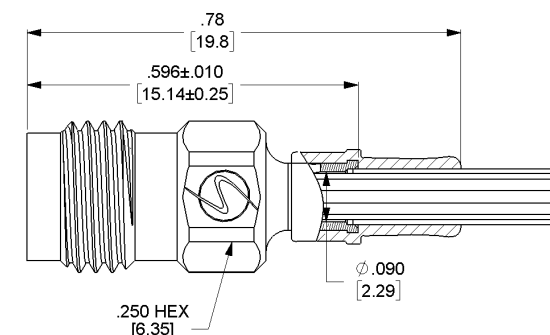

Description

2.92 mm Jack for .141 Cable

Part Number

CN-21-141-01

Electrical

Frequency : DC – 40 GHz

VSWR : 1.30:1, Max

I.L. : 0.25 dB, Max

Mechanical

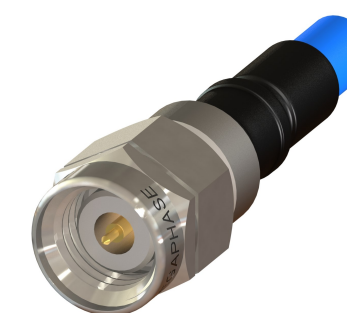
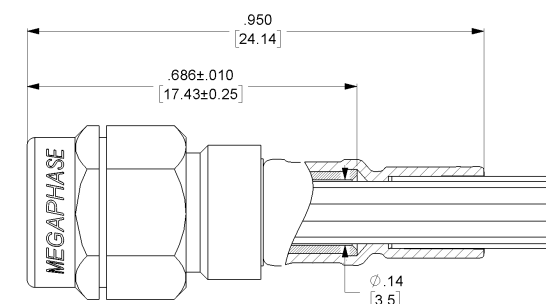

Description

2.4mm Plug for .141 Cable

Part Number

CN-22-141-01

Electrical

Frequency : DC – 40 GHz

VSWR : 1.30:1, Max

I.L. : 0.25 dB, Max

Mechanical

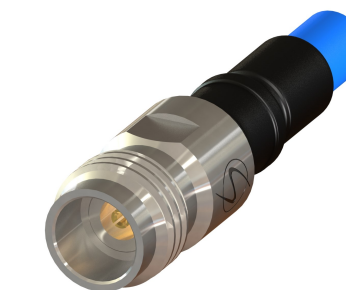
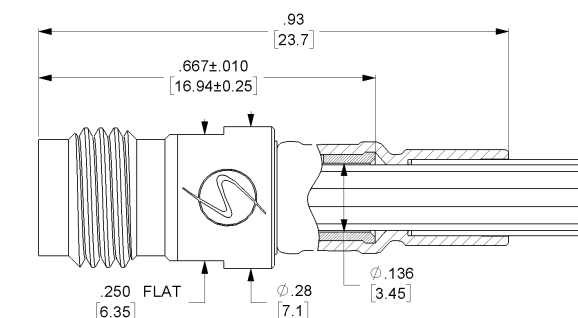



Cable Connectors

2.4 mm Hermetic



2.4 mm Plug

2.4 mm Jack

Waterproof 2.4mm designs offer a compact connector envelope, watertight in unmated conditions, with the ability to withstand rain, 100% condensation, and water submersion up to 1m depth. Every potential water ingress path is mitigated with at least two waterproofing methods to maintain long-lasting performance under extreme environmental conditions.

Component	Material	Finish
Contacts :	Beryllium Copper Per C17300	Gold Plated Per ASTM B- Type 2, Code C, 50-100 µin Thick Over Nickel Plated Per SAE-AMS-QQ-N-290, Class I. 50-100 µin Thick
Bodies :	Steel Corrosion Resistant, Non Magnetic ASTM-A-585 UNS NO. S30300	Passivated SEA - AMS - 2700 Method 1, Type 2
Hermetic Bead :	Glass, Corning 7070 & Kovar	None
Solder Adaptors :	Steel Corrosion Resistant, Non Magnetic ASTM-A-585 UNS NO. S30300	Gold Plated Per ASTM B- Type 2, Code C, 50-100 µin Thick Over Nickel Plated Per SAE-AMS-QQ-N-290, Class I. 50-100 µin Thick
Nuts :	Steel Corrosion Resistant, Non Magnetic ASTM-A-585 UNS NO. S30300	Passivated SEA - AMS - 2700 Method 1, Type 2
Snap-Rings :	Beryllium Copper Per C17300	Heat Treated
Gasket :	Silicon Rubber per A-A-59588, Class 2B, Graded 50, 50±5 Durometre	None
O-Rings :	Silicon Rubber per A-A-59588, Class 1B, Graded 70	None



Cable Connectors

Description

2.4 mm Plug for .141 Cable

Part Number

CN-21-086-02H

Electrical

Frequency : DC – 40 GHz

VSWR : 1.37:1, Max

I.L. : 0.3 dB, Max

Mechanical

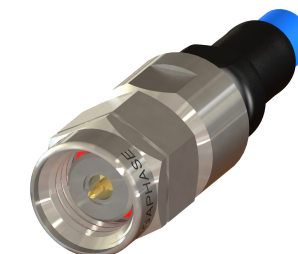
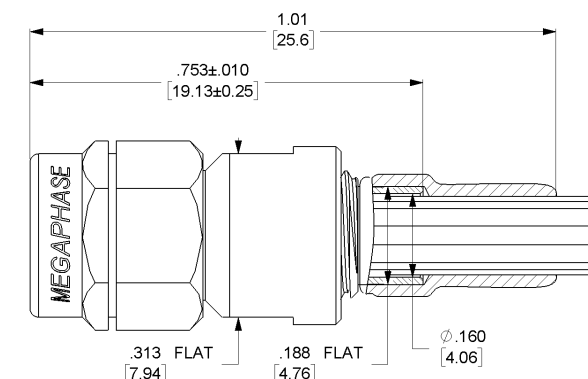

Description

2.4 mm Jack for .141 Cable

Part Number

CN-22-086-02H

Electrical

Frequency : DC – 40 GHz

VSWR : 1.37:1, Max

I.L. : 0.3 dB, Max

Mechanical

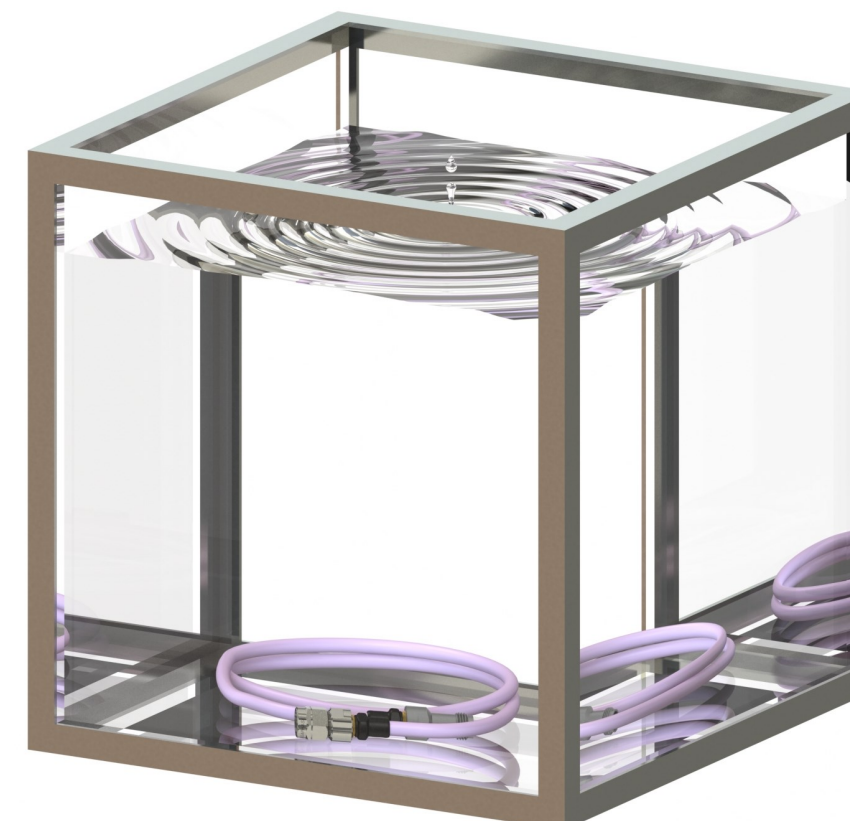
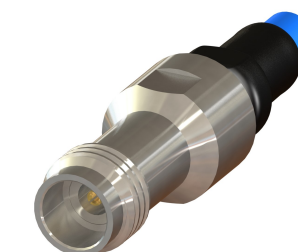
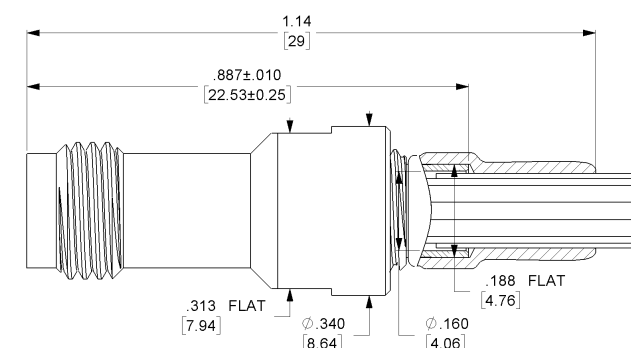



Cable Connectors

2.4 mm Ruggedized

2.4 mm Jack

2.4 mm Plug

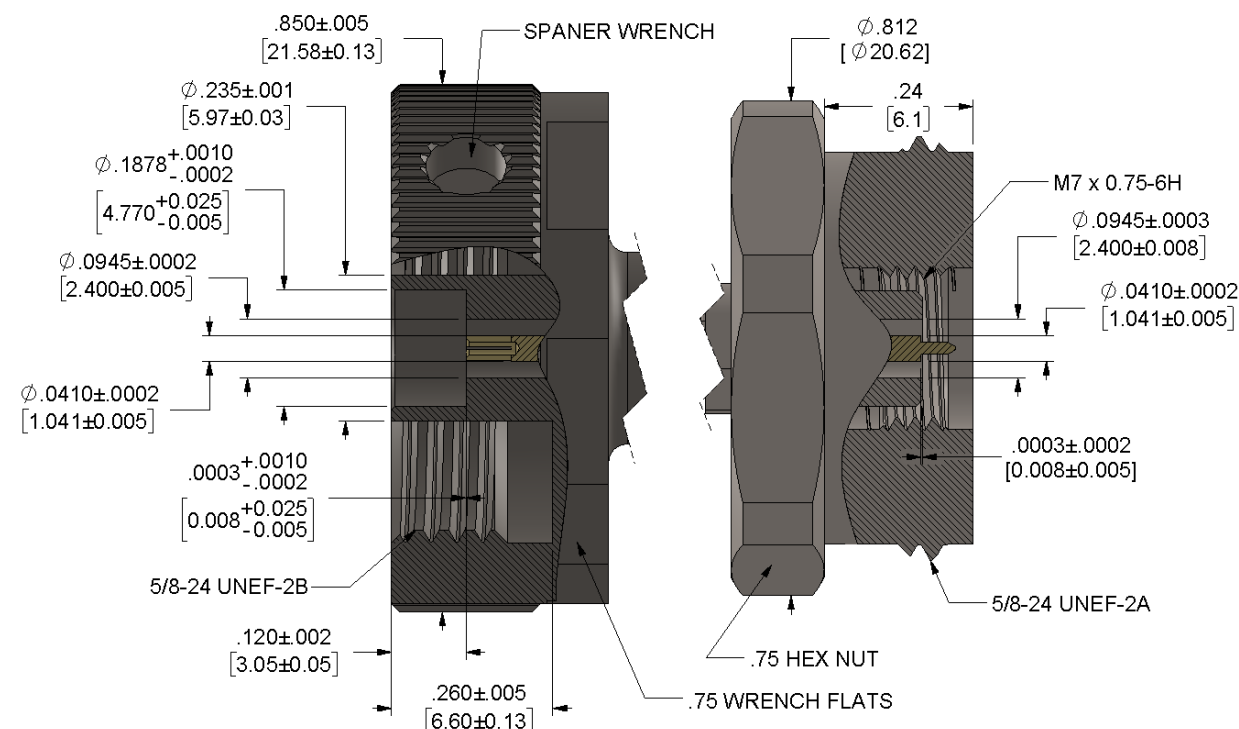

Component	Material	Finish
Contacts :	Beryllium Copper Per C17300	Gold Plated Per ASTM B- Type 2, Code C, 50-100 μ m Thick Over Nickel Plated Per SAE-AMS-QQ-N-290, Class I. 50-100 μ m Thick
Bodies :	Steel Corrosion Resistant, Non Magnetic ASTM-A-585 UNS NO. S30300	Passivated SEA - AMS - 2700 Method 1, Type 2
Hermetic Bead :	Glass, Corning 7070 & Kovar	None
Solder Adaptors :	Steel Corrosion Resistant, Non Magnetic ASTM-A-585 UNS NO. S30300	Gold Plated Per ASTM B- Type 2, Code C, 50-100 μ m Thick Over Nickel Plated Per SAE-AMS-QQ-N-290, Class I. 50-100 μ m Thick
Nuts :	Steel Corrosion Resistant, Non Magnetic ASTM-A-585 UNS NO. S30300	Passivated SEA - AMS - 2700 Method 1, Type 2
Snap-Rings :	Beryllium Copper Per C17300	Heat Treated
Gasket :	Silicon Rubber per A-A-59588, Class 2B, Graded 50, 50±5 Durometre	None
O-Rings :	Silicon Rubber per A-A-59588, Class 1B, Graded 70	None



Cable Connectors

Description

2.4 mm Jack for .086 Cable

Part Number

CN-21-086-02H

Electrical

Frequency : DC – 50 GHz

VSWR : 1.35:1, Max

I.L. : 0.3 dB, Max

Mechanical

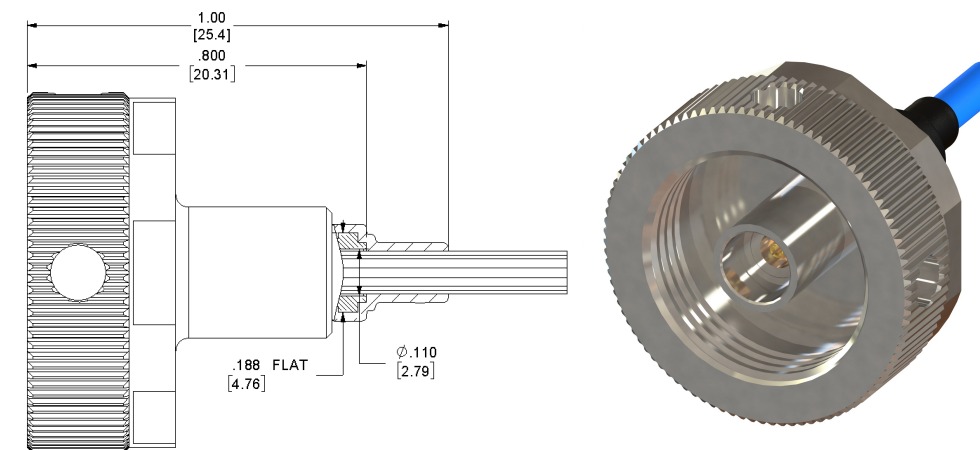

Description

2.4 mm Plug for .086 Cable

Part Number

CN-22-086-02H

Electrical

Frequency : DC – 50 GHz

VSWR : 1.35:1, Max

I.L. : 0.3 dB, Max

Mechanical

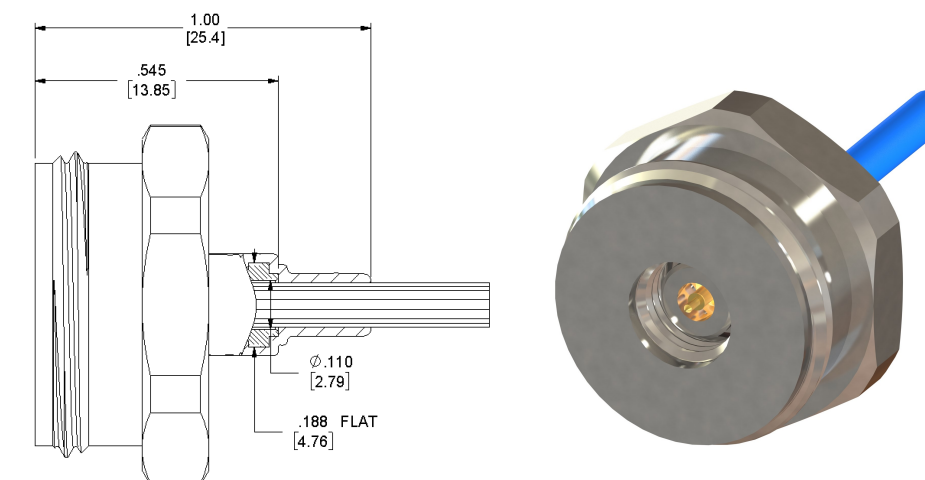



Cable Connectors

2.92 mm Interface

2.92 mm Jack

2.92 mm Plug

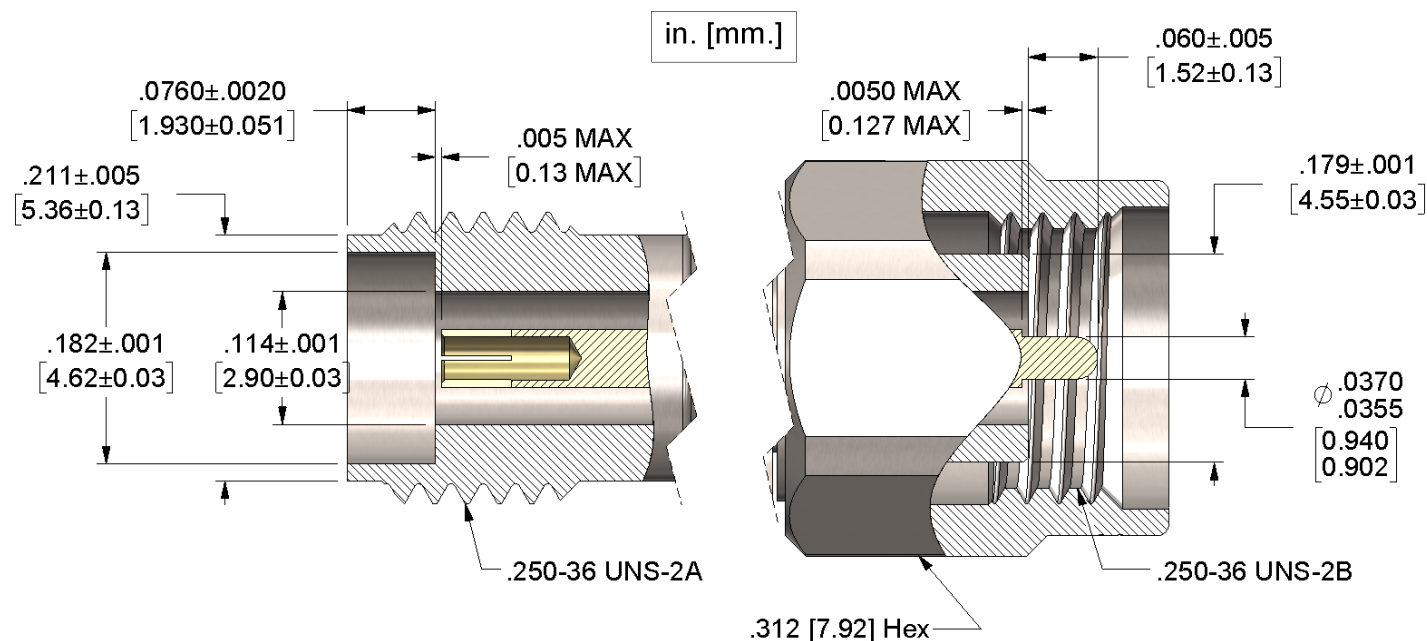

Component	Material	Finish
Contacts :	Beryllium Copper Per C17300	Gold Plated Per ASTM B- Type 2, Code C, 50-100 μin Thick Over Nickel Plated Per SAE-AMS-QQ-N-290, Class I. 50-100 μin Thick
Bodies :	Steel Corrosion Resistant, Non Magnetic ASTM-A-585 UNS NO. S30300	Passivated SEA - AMS - 2700 Method 1, Type 2
Insulators 1 :	Polyetherimide Resin General Electric Ultem 1000 ASTM D-5205	None
Insulators 2 :	Teflon, PTFE Per ASTM-D1710	None
Solder Adaptors :	Steel Corrosion Resistant, Non Magnetic ASTM-A-585 UNS NO. S30300	Gold Plated Per ASTM B- Type 2, Code C, 50-100 μin Thick Over Nickel Plated Per SAE-AMS-QQ-N-290, Class I. 50-100 μin Thick
Nuts :	Steel Corrosion Resistant, Non Magnetic ASTM-A-585 UNS NO. S30300	Passivated SEA - AMS - 2700 Method 1, Type 2
Snap-Rings :	Beryllium Copper Per C17300	Heat Treated



Cable Connectors

Description

2.92 mm Plug for .086 Cable

Part Number

CN-K1-086-01

Electrical

Frequency : DC – 40 GHz

VSWR : 1.25:1, Max

I.L. : 0.25 dB, Max

Mechanical

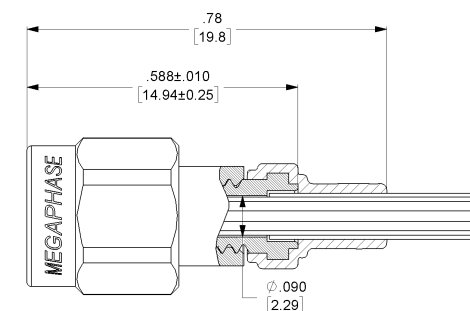

Description

2.92 mm Jack for .086 Cable

Part Number

CN-K2-086-01

Electrical

Frequency : DC – 40 GHz

VSWR : 1.25:1, Max

I.L. : 0.25 dB, Max

Mechanical

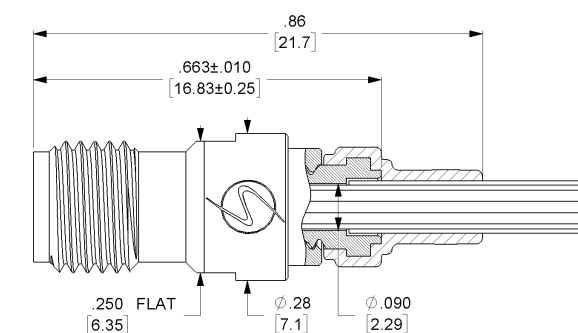

Description

2.92 mm Plug for .141 Cable

Part Number

CN-K1-141-01

Electrical

Frequency : DC – 40 GHz

VSWR : 1.25:1, Max

I.L. : 0.25 dB, Max

Mechanical

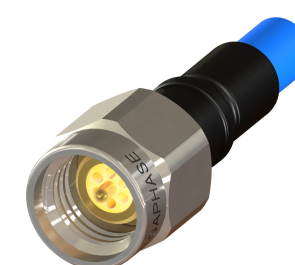
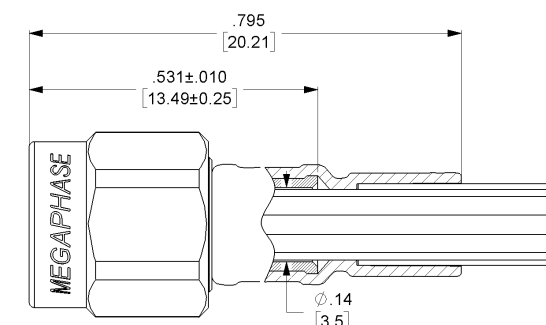

Description

2.92 mm Jack for .141 Cable

Part Number

CN-K2-141-01

Electrical

Frequency : DC – 40 GHz

VSWR : 1.25:1, Max

I.L. : 0.25 dB, Max

Mechanical

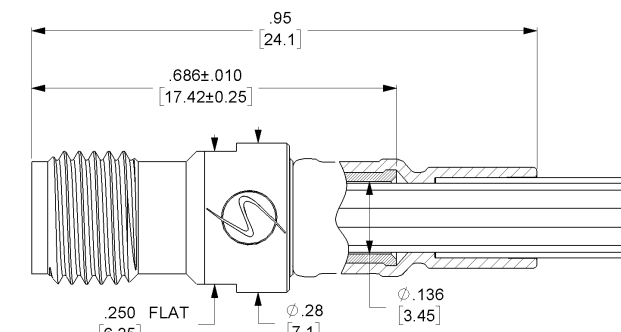



PCB CONNECTION

Strong Grounding For High Reliability System



Matrix

	Edge Mount	Surface Mount
SMP	Pages : 40 - 41	Pages : 42 - 43
SMPM	Pages : 44 - 45	Pages : 46

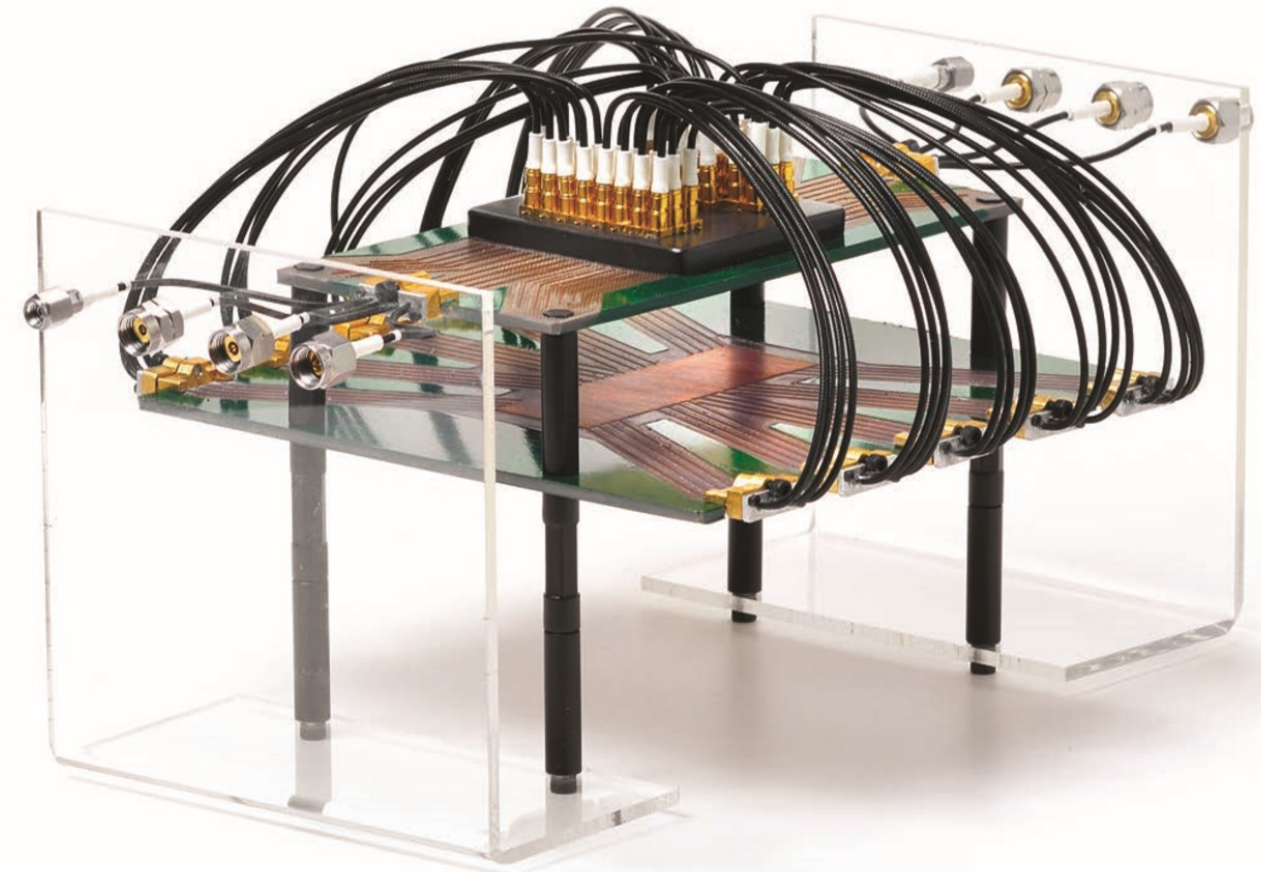



SMP Male Edge Mount

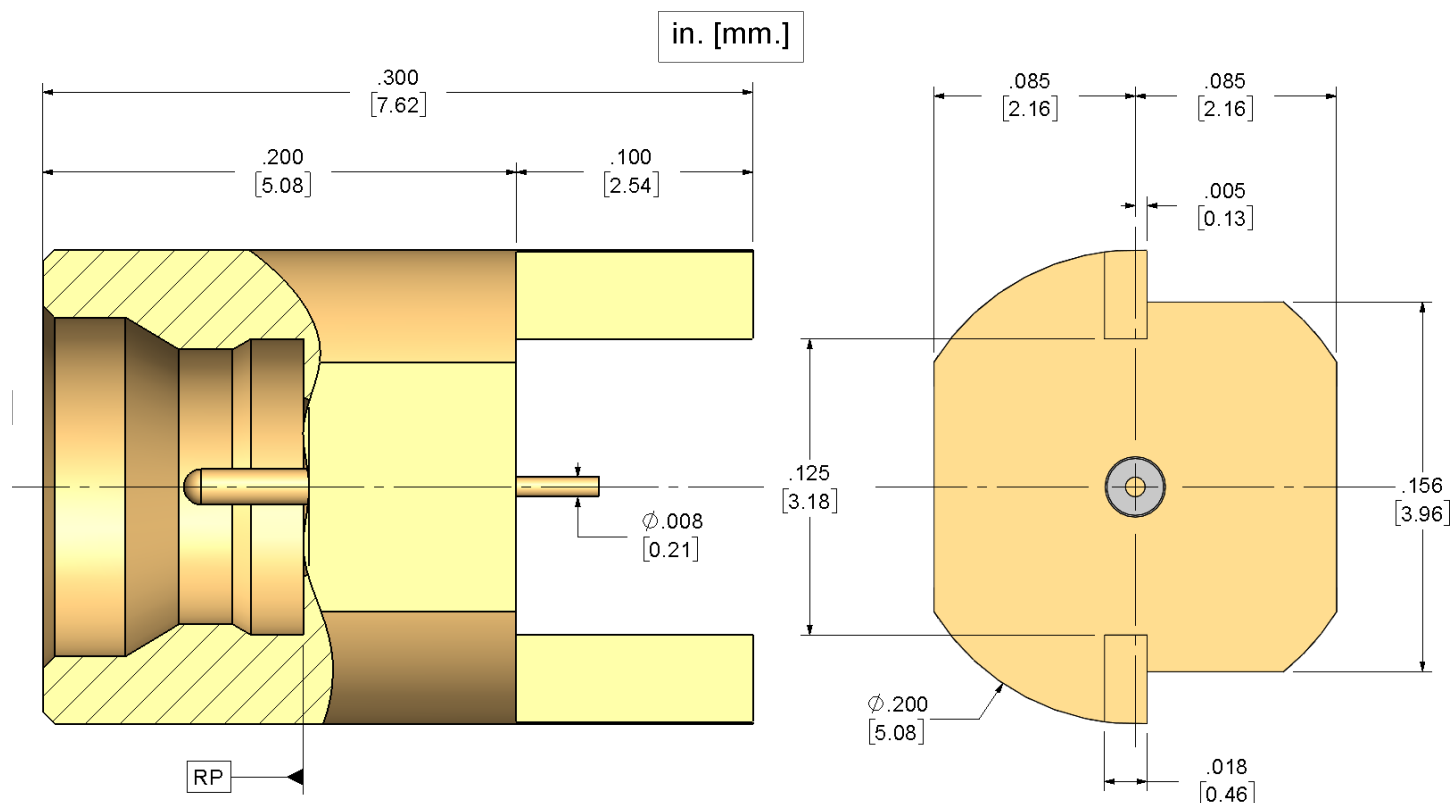

Component	Material	Finish
Contacts :	Beryllium Copper Per C17300	Gold Plated Per ASTM B- Type 2, Code C, 50-100 μ m Thick Over Nickel Plated Per SAE-AMS-QQ-N-290, Class I. 50-100 μ m Thick
Bodies :	Beryllium Copper Per C17300	Gold Plated Per ASTM B- Type 2, Code C, 50-100 μ m Thick Over Nickel Plated Per SAE-AMS-QQ-N-290, Class I. 50-100 μ m Thick
Insulators :	Teflon, PTFE Per ASTM-D1710	None



Description

SMP Male Edge Mount
Full Detente

Part Number

CP-GE1-01F

Electrical

Frequency : DC – 40 GHz

Mechanical

N/A

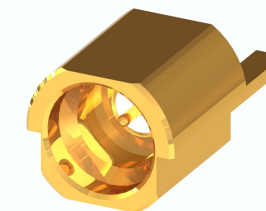
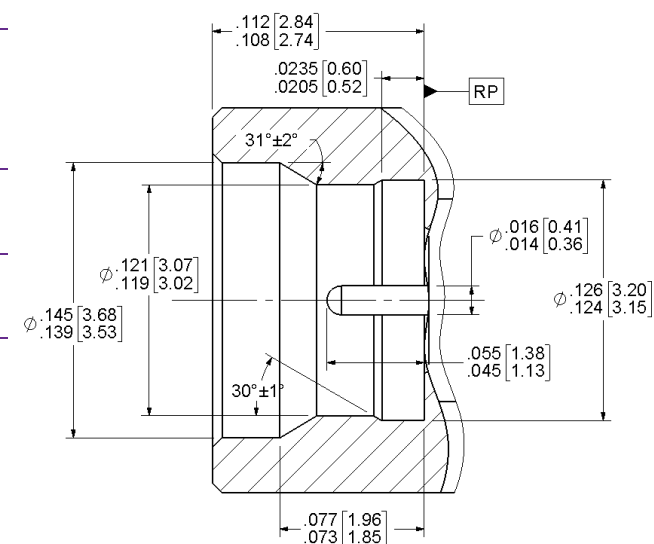

Description

SMP Male Edge Mount
Limited Detente

Part Number

CP-GE1-01L

Electrical

Frequency : DC – 40 GHz

Mechanical

N/A

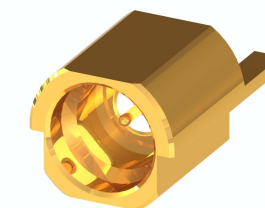
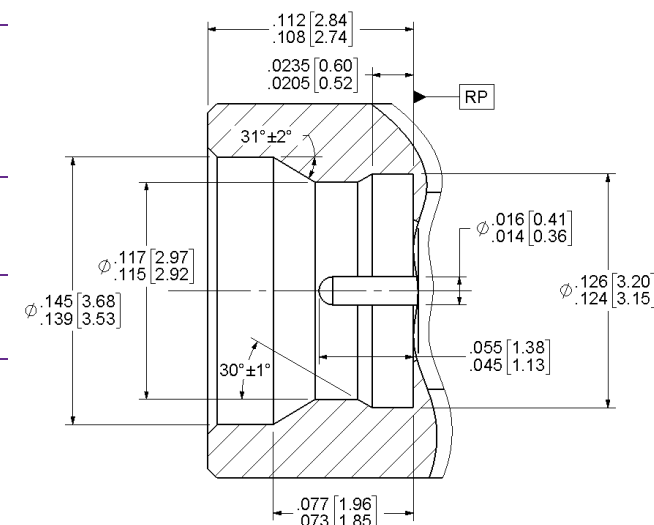

Description

SMP Male Edge Mount
Smooth Bore

Part Number

CP-GE1-01S

Electrical

Frequency : DC – 40 GHz

Mechanical

N/A

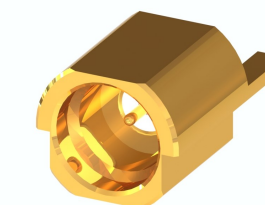
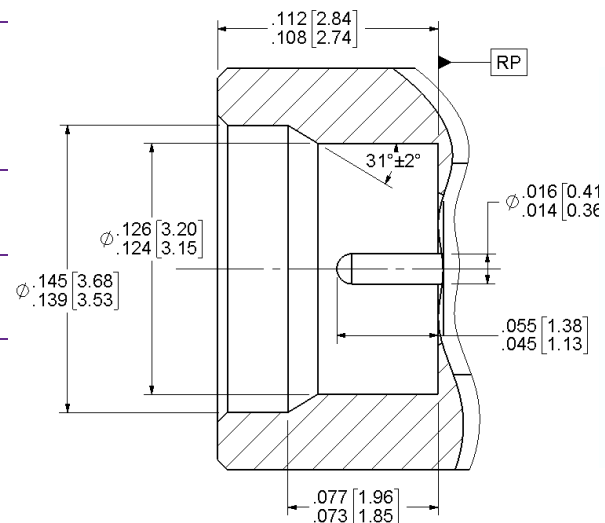



PCB Connectors

SMP Male Surface Mount

in. [mm.]

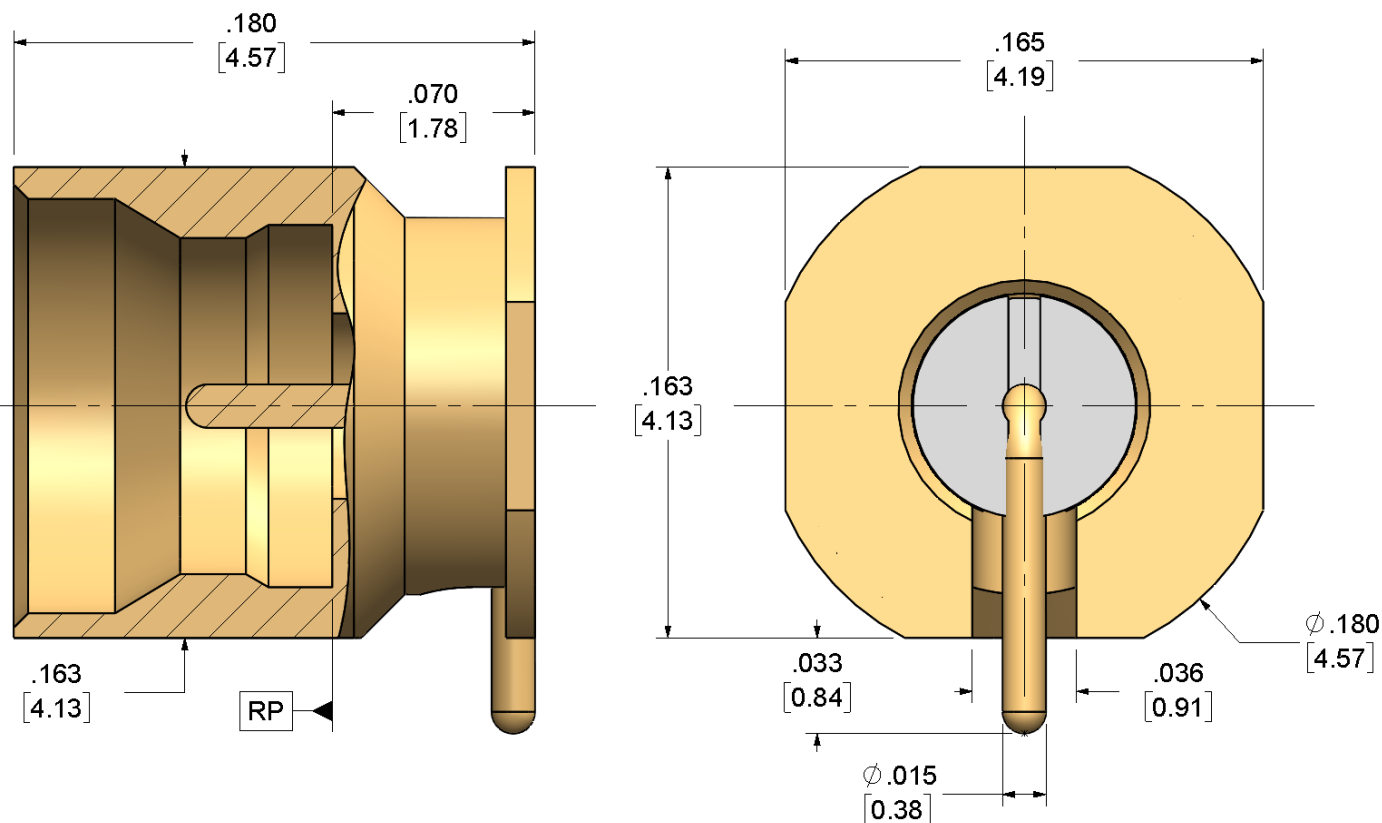

Component	Material	Finish
Contacts :	Beryllium Copper Per C17300	Gold Plated Per ASTM B- Type 2, Code C, 50-100 µin Thick Over Nickel Plated Per SAE-AMS-QQ-N-290, Class I. 50-100 µin Thick
Bodies :	Beryllium Copper Per C17300	Gold Plated Per ASTM B- Type 2, Code C, 50-100 µin Thick Over Nickel Plated Per SAE-AMS-QQ-N-290, Class I. 50-100 µin Thick
Insulators :	Teflon, PTFE Per ASTM-D1710	None
Nuts :	Steel Corrosion Resistant, Non Magnetic ASTM-A-585 UNS NO. S30300	Passivated SEA - AMS - 2700 Method 1, Type 2



PCB Connectors

Description

SMP Male Surface Mount
Limited Detente

Part Number

CP-GE3-01L

Electrical

Frequency : DC – 40 GHz

Mechanical

N/A

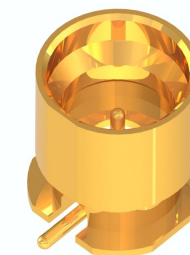
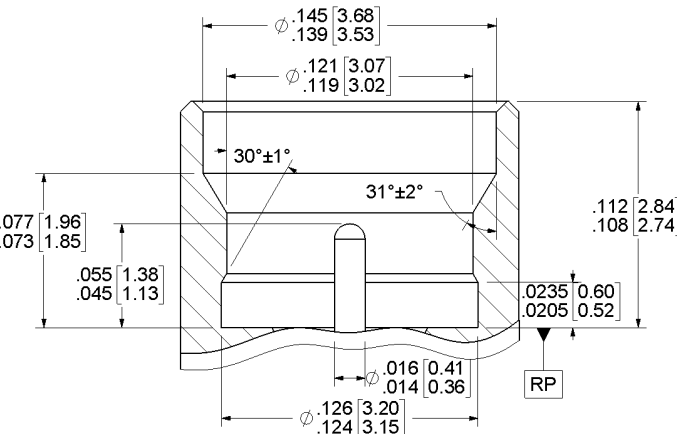

Description

SMP Male Surface Mount
Smooth Bore

Part Number

CP-GE3-01S

Electrical

Frequency : DC – 40 GHz

Mechanical

N/A

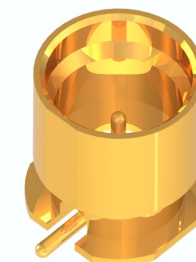
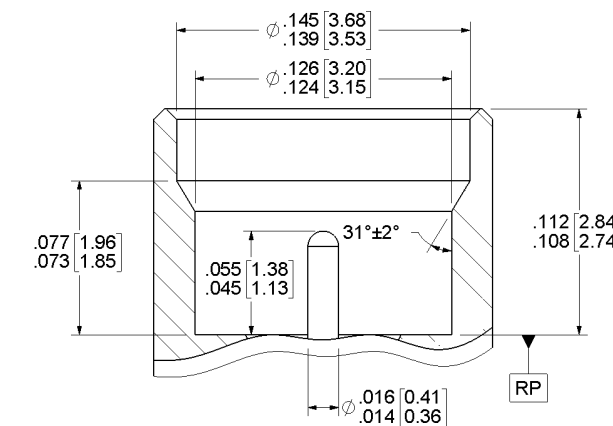



PCB Connectors

SMPM Male Edge Mount

in. [mm.]

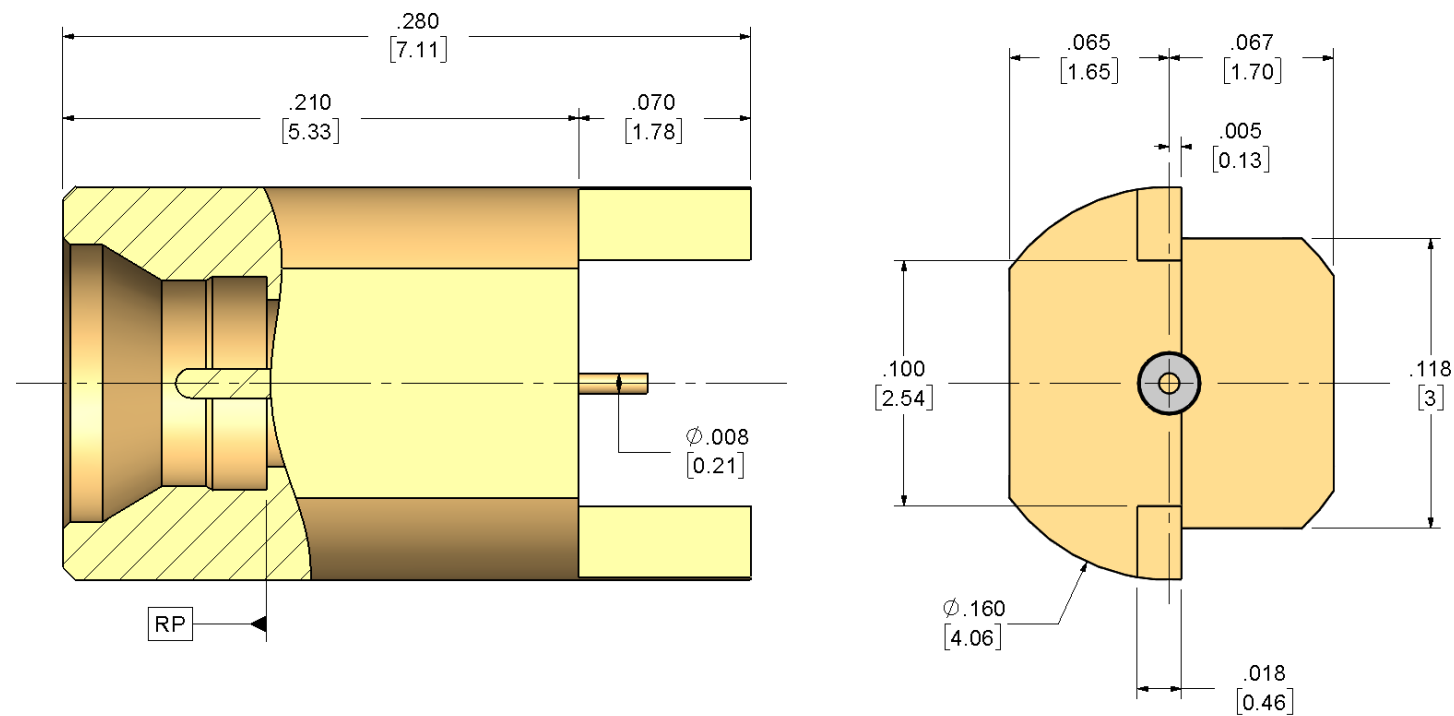

Component	Material	Finish
Contacts :	Beryllium Copper Per C17300	Gold Plated Per ASTM B- Type 2, Code C, 50-100 μ m Thick Over Nickel Plated Per SAE-AMS-QQ-N-290, Class I. 50-100 μ m Thick
Bodies :	Beryllium Copper Per C17300	Gold Plated Per ASTM B- Type 2, Code C, 50-100 μ m Thick Over Nickel Plated Per SAE-AMS-QQ-N-290, Class I. 50-100 μ m Thick
Insulators :	Teflon, PTFE Per ASTM-D1710	None



PCB Connectors

Description

SMPM Male Edge Mount
Full Detente

Part Number

CP-GSE1-01F

Electrical

Frequency : DC – 65 GHz

Mechanical

N/A

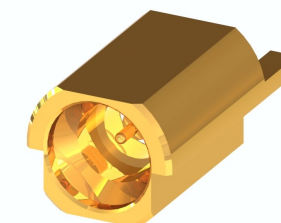
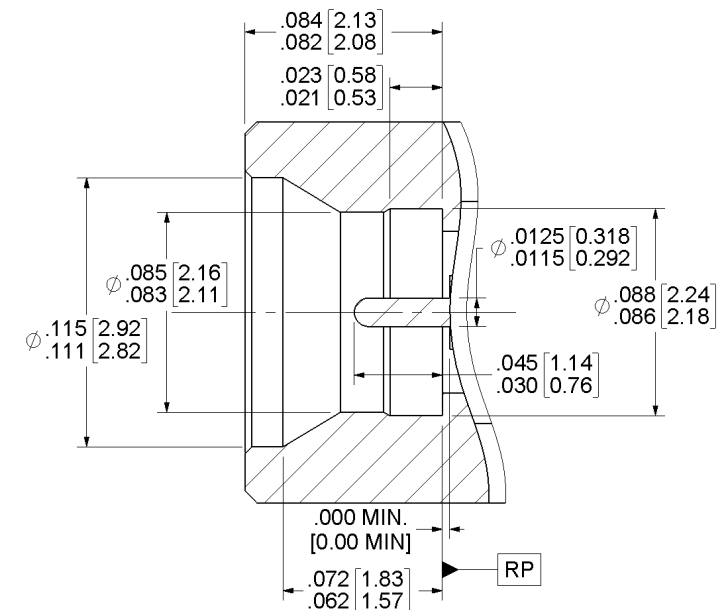

Description

SMPM Male Edge Mount
Smooth Bore

Part Number

CP-GSE1-01S

Electrical

Frequency : DC – 65 GHz

Mechanical

N/A

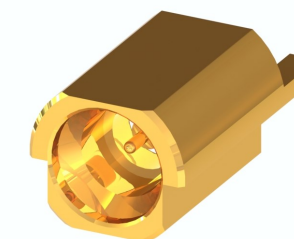
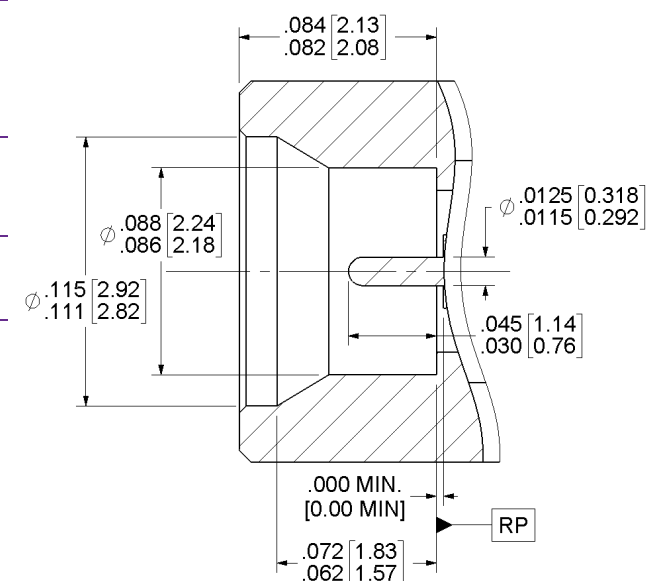



PCB Connectors

SMPM Male Surface Mount

in. [mm.]

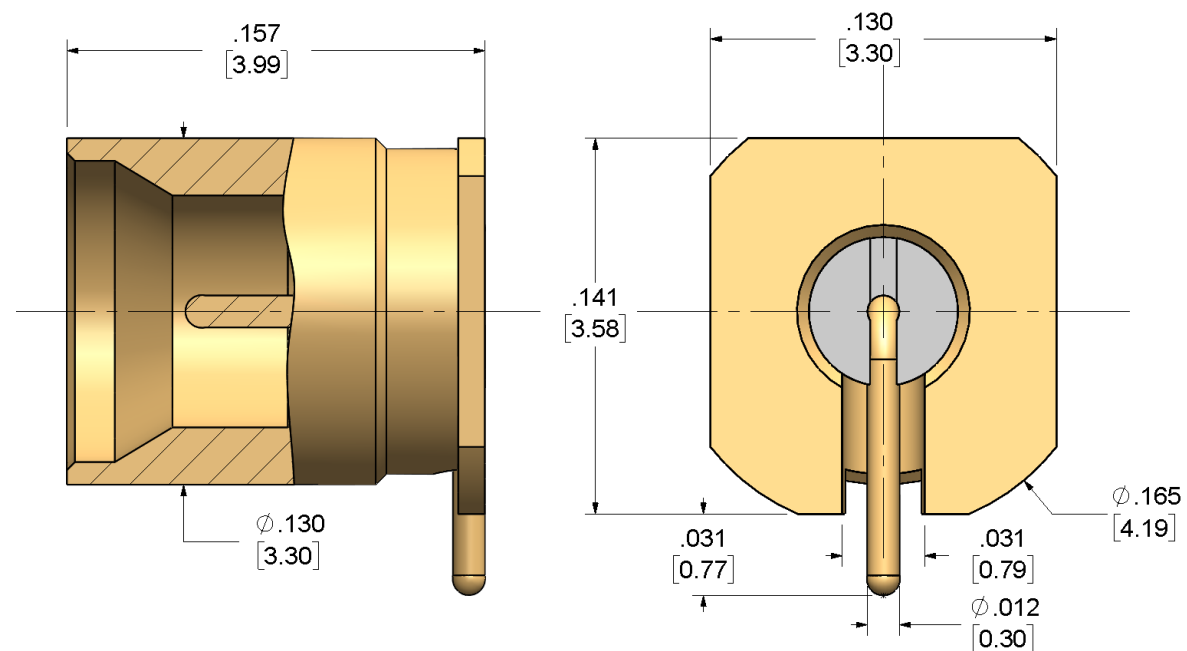

Component	Material	Finish
Contacts :	Beryllium Copper Per C17300	Gold Plated Per ASTM B- Type 2, Code C, 50-100 μ m Thick Over Nickel Plated Per SAE-AMS-QQ-N-290, Class I. 50-100 μ m Thick
Bodies :	Beryllium Copper Per C17300	Gold Plated Per ASTM B- Type 2, Code C, 50-100 μ m Thick Over Nickel Plated Per SAE-AMS-QQ-N-290, Class I. 50-100 μ m Thick
Insulators :	Teflon, PTFE Per ASTM-D1710	None

Description

SMPM Male Surface Mount
Smooth Bore

Part Number

CP-GSE3-01S

Electrical

Frequency : DC – 65 GHz

Mechanical

N/A

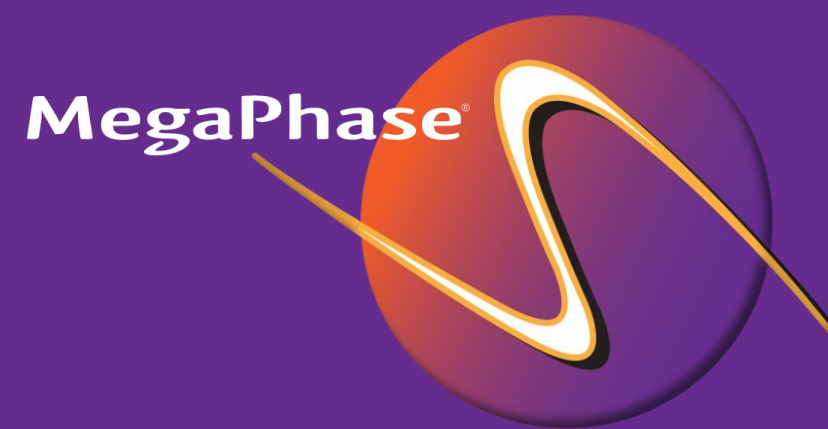
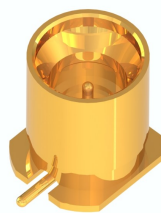
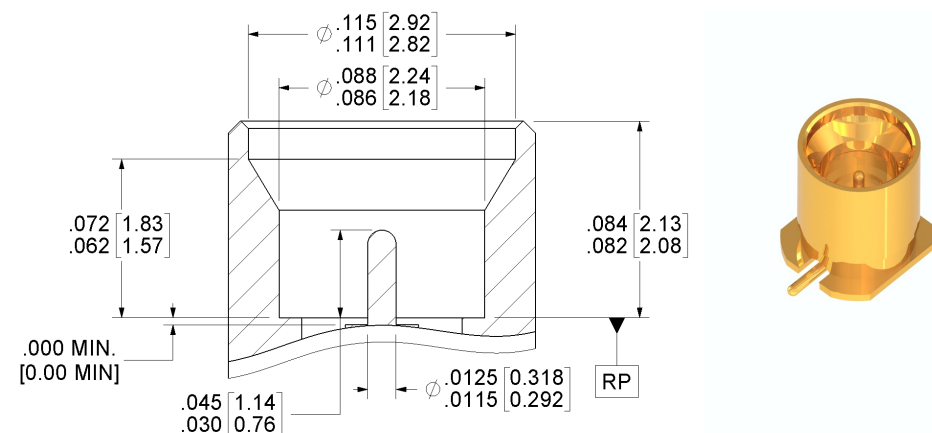

Because your style matters





122 Banner Road, Stroudsburg, PA 18360-6433
TEL: 1-877-634-2742 | 570-424-8400
solutions@megaphase.com | www.megaphase.com

